



FF4EuroHPC Success Stories

SME Innovation Through HPC

2nd Edition

Index

FF4EuroHPC Success Stories SME Innovation Through HPC 2nd Edition, September 2023

Publisher: Arctur on behalf of the FF4EuroHPC Consortium

Published: in 2023

Edition: 2nd

Copyright © 2023 Members of FF4EuroHPC Consortium

Text Copyright © 2023 Members of FF4EuroHPC Consortium

Editor: Members of FF4EuroHPC Consortium

Number of copies: 600

CIP - Kataložni zapis o publikaciji
Narodna in univerzitetna knjižnica, Ljubljana

004.9:334.012.6-022.51
004.7:005

FF4EUROHPC success stories : SME innovation through
HPC / [editor members of FF4EuroHPC Consortium].
- 2nd ed. - Nova Gorica : Arctur on behalf of the
FF4EuroHPC Consortium, 2023

ISBN 978-961-94587-4-7
COBISS.SI-ID 162217987

4	Chapter 1: About the FF4EuroHPC Project
6	Chapter 2: FF4EuroHPC Core Partners
8	Chapter 3: FF4EuroHPC Experiment Partners
12	Chapter 4: FF4EuroHPC Success Stories
102	Chapter 5: List of Abbreviations



EuroHPC
Joint Undertaking



This project has received funding from the European High-Performance Computing Joint Undertaking (JU) under grant agreement No 951745. The JU receives support from the European Union's Horizon 2020 research and innovation programme and Germany, Italy, Slovenia, France, Spain.

www.ec.europa.eu

www.ff4eurohpc.eu



About the FF4EuroHPC Project

The FF4EuroHPC project has received funding from the European High Performance Computing Joint Undertaking (JU) under grant agreement No 951745. The JU receives support from the European Union's Horizon 2020 research and innovation programme and Germany, Italy, Slovenia, France, Spain. The total funding is 9.9 Million EUR. The project started in September 2020 and its duration is 38 months. The project is coordinated by the University of Stuttgart/HLRS (Germany) and supported by 5 other core partners: Arctur (Slovenia), CINECA (Italy), CESGA (Spain), scapos AG (Germany) and Teratec (France).

The Aim of the FF4EuroHPC Project

FF4EuroHPC helps facilitate access to High-Performance Computing-related technologies for European Small & Medium Enterprises (SMEs) and thus increases the innovation potential of European industry. Whether an SME is running high resolution simulations, doing large-scale data analyses, or incorporating Artificial Intelligence applications into its business or service workflows, FF4EuroHPC assists them to connect their business with cutting-edge technologies.

SME Participation

Two open calls were implemented through the project targeting the highest quality experiments involving innovative, agile SMEs. The focus was put particularly on



SMEs from the manufacturing and engineering sectors but also on other key European industrial sectors. Each experiment was centred on an end-user SME (or consulting SME) and the consortium was completed by technology or service providers such as ISVs, technology and domain experts, and HPC providers. The experiment partners identified and addressed a specific business challenge for the SME linked to a specific industrial sector (or in some cases for multiple industrial sectors). By implementing HPC, Artificial Intelligence (AI), Machine Learning (ML), High-Performance Data Analytics (HPDA), or other state-of-the-art technologies, the experiment partners were able to develop unique products, innovative business opportunities, and become more competitive.

Experiments and Success Stories

In total, 42 experiments met the open call requirements, successfully passed the evaluation process, and were selected for funding. During the 15-month duration of an experiment, the experiment partners jointly worked on the relevant use case and strove to overcome the challenges with the help of HPC. In the first Open Call, 16 experiments ran, involving 53 partners from 9 European countries. In the second Open Call, 26 experiments ran, involving 79 partners from 22 European countries. All 42 experiments were successfully concluded and are presented in this booklet. Each experiment had to address SME business challenges by using HPC and complementary technologies such as HPDA and AI. Therefore, each was an End User-relevant case study demonstrating the use of HPC and the benefits it brings to the value chain from the end-user to the HPC-infrastructure provider. As soon as the experiment was successfully concluded, it generated a success story, which highlights the expected business benefits for the participating SMEs. The success story also presents the potential impact of the experiment's results in terms of economic, societal, and environmental challenges. Thus, it provides an inspiration to the broader industrial community.





FF4EuroHPC Core Partners

FF4EuroHPC core partners supported participating experiment partners in accessing HPC-resources, as well as planning, implementing, realising, and promoting their experiments. CESGA, CINECA, and HLRS partners also acted as a provider of High-Performance Computing resources and expertise in some experiments. Furthermore, FF4EuroHPC partners connected SMEs with the National Competence Centers (NCCs). NCCs closely collaborated with SMEs to identify new business challenges and partners and support the implementation of the appropriate actions to foster the use of HPC by SMEs.

ARCTUR

Arctur is a Research & Development oriented SME active in the field of Information and Communications Technology. Arctur is the main Slovenian commercial supplier of HPC services and solutions. Arctur has its own infrastructure to be used as the technological foundation for advanced HPC and Cloud computing solutions and innovative web services in a distributed, high-redundancy environment. The company has extensive experience in server virtualization and deployment, integration of disparate IT systems, IT support of project management, and server farm leverage for the deployment of SaaS specialized for SMEs.

www.arctur.si



CESGA

Galicia Supercomputing Center's mission is to contribute to the advancement of Science and Technical Knowledge by means of research and application of HPC and communications, as well as other information technology resources, in collaboration with other institutions for the profit of society. In general, the purposes of CESGA are all those that promote the research in and use of HPC, advanced communications, and the development of information and communications technologies as an instrument for sustainable socioeconomic development.

www.cesga.es



CINECA

CINECA is the largest Italian supercomputing centre with an HPC environment equipped with cutting-edge technology and highly qualified personnel which cooperates with academia and industrial partners. CINECA's mission is to enable the Italian and European research community to accelerate scientific discovery using HPC resources in a profitable way, exploiting the newest technological advances in HPC, data management, storage systems, tools, services, and expertise at large.

www.cineca.it



HLRS

The High-Performance Computing Center Stuttgart (HLRS) was established in 1996 as the first German national high-performance computing center, building on a tradition of supercomputing at the University of Stuttgart that stretches back to 1959. As a research institution affiliated with the University of Stuttgart and a founding member of the Gauss Centre for Supercomputing — the alliance of Germany's three national supercomputing centers — HLRS provides state-of-the-art HPC services to academic users and industry. HLRS operates one of Europe's most powerful supercomputers, provides advanced training in HPC programming and simulation, and conducts research to address key problems facing the future of supercomputing.

www.hlrs.de



Scapos AG

Scapos AG is a German SME. Its business is the distribution of advanced software solutions, particularly from research and academic institutes. Its product portfolio includes optimisation software, computer-aided engineering, and libraries for HPC. Its worldwide customers range from industrial corporations and large research institutes to SMEs. Its activities in HPC R&D projects complement the above and target service provision and the development of new business opportunities.

www.scapos.com



TERATEC

TERATEC is a non-profit European pillar of expertise in HPC, numerical simulation, and Data Analytics, and brings together more than eighty technological and industrial companies, laboratories and research centres, and universities that wish to combine their resources in the strategic field of HPC and simulation. It forms the core of a Research & Development technology park and is a member of the "SYSTEMATIC Paris Region" industrial cluster.

www.teratec.eu





FF4EuroHPC Experiment Partners



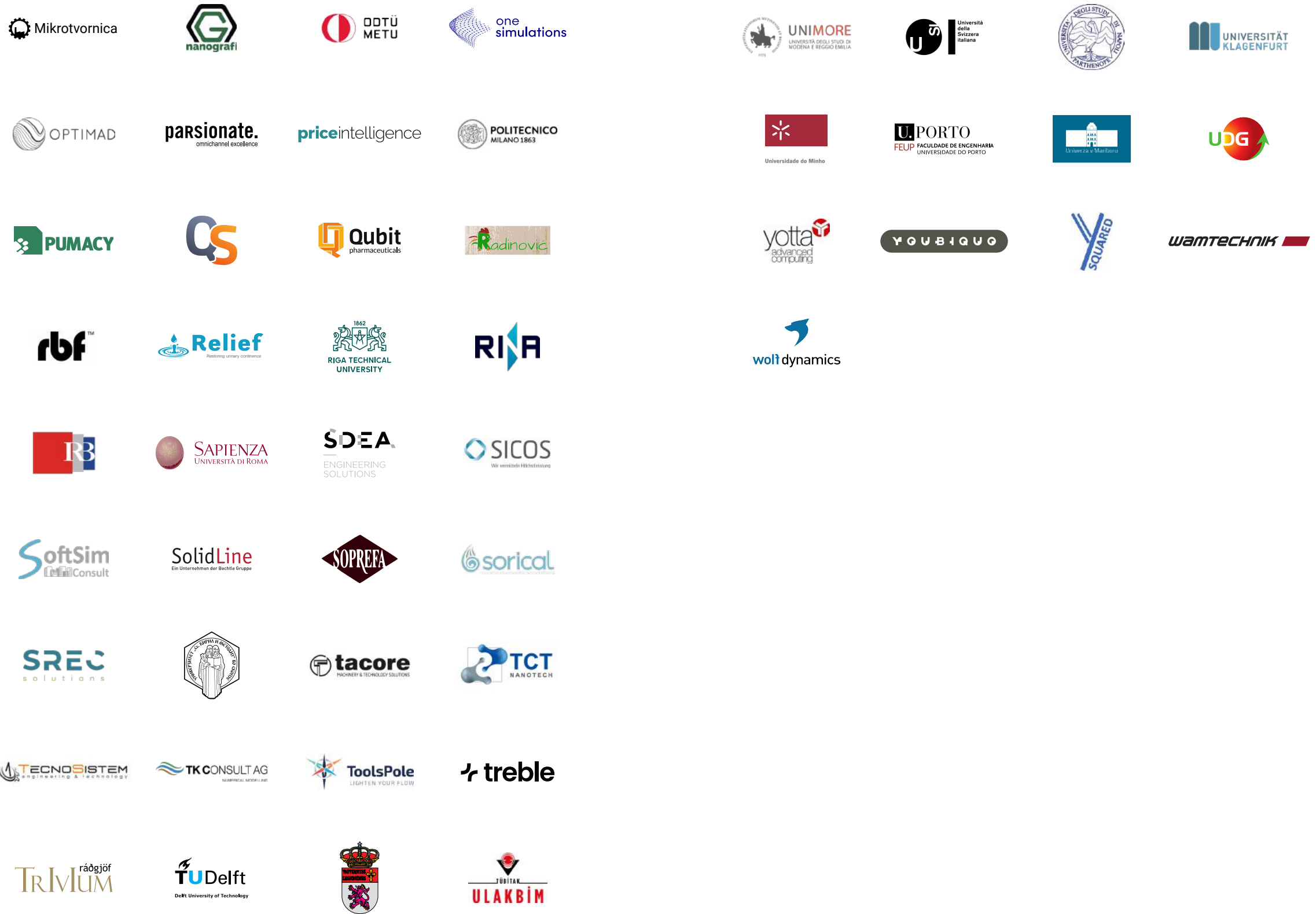



FF4EuroHPC Success Stories

- 16 Accelerated Structural Design of Sustainable Aviation Projects
[ElevonX, Slovenia](#)
- 18 AI/ML Computer Vision for the Next Generation Hen Farms
[Radinovic & Meso-Promet-Franca, Montenegro](#)
- 20 Improvement of Productivity in Aquaculture
[Nueva Pescanova- Insuiña & Geneaqua, Spain](#)
- 22 HPC-based Engineering Design for Control of Smoke in Subway Tunnels
[TECNOSISTEM S.p.A, Italy](#)
- 24 Cloud-Based CFD for Urban Microclimate Assessment and Architectural Planning
[SoftSim Consult, Bulgaria](#)
- 26 Accessible Acoustic Simulation Platform to Create Better Sound Experiences
[Trivium, Iceland](#)
- 28 Leveraging HPC for AI and Deep Learning Powered Solutions for Asset Management
[Axyon AI, Italy](#)
- 30 Market Innovation Sourcing
[Parsionate, Germany](#)
- 32 Robust Power System Maintenance Planning via Stochastic Optimization and HPC
[Artelys, France](#)
- 34 Optimising Performance of Air-Cooled Condensers Using Wind Shields
[Galebreaker, United Kingdom](#)
- 36 Accelerating CFD Simulation of Immersive Battery Cooling
[Wamtechnik, Poland](#)
- 38 Beyond Molecular Dynamics Simulations and Analysis for Battery Materials Development
[Enerpoly, Sweden](#)
- 40 Optimal CO2 Capture and Utilization Plant Design Through HPC
[Y Squared , Greece](#)
- 42 High-Fidelity Modelling of a Hydrogen-Fired Industrial Combustor
[E&M Combustion , Spain](#)
- 44 HPC-Based Navigation System for Marine Litter Hunting
[Green Tech Solution, Italy](#)
- 46 AI-Aided Wind Flow and Gas Dispersion Simulations in Cities
[Bettair Cities, Spain](#)
- 48 Reservoir Monitoring by AI-Enabled Exploitation of Satellite Imagery
[SORICAL, Italy](#)
- 50 High Fidelity Modeling for Small Wind Turbines
[EUNICE Wind, Greece](#)
- 52 Solving Ambitious Challenges in Wastewater Treatment Using HPC in CFD Simulation
[Holinger Group & Elkuch Group, Switzerland & Liechtenstein](#)
- 54 A Pediatric Simulated Dosimetry Platform for Clinical Use
[iKnowHow, Greece](#)
- 56 Advanced HPC Based Drug Discovery with Converged Deep Physics and AI
[Iktos, France](#)
- 58 Cloud-Based HPC Platform to Support Systemic-Pulmonary Shunting Procedures
[InSilicoTrials Technologies, Italy](#)
- 60 High-Performance Computing Enhances Treatment Precision in Breast Cancer
[CHOSA, United Kingdom](#)
- 62 HPC Simulation for an Endourethral Sphincter Against Urinary Incontinence
[Relief, Italy](#)
- 64 Application of HPC Tools for the Optimization of 3D-Printed Orthopaedic Devices
[CastPrint, Latvia](#)
- 66 Real-Time Heart Monitoring of Thousands of Patients
[Innovation Dooel, North Macedonia](#)
- 68 A Digital Twin for Airflow and Inhaled Drug Delivery in Human Airways
[One Simulations, The Netherlands](#)
- 70 AI-Platform for Automated Training of Object Detection Models Based on CAD Data
[Gabler Engineering & Kimoknow, Germany](#)
- 72 Multiphysics and Multiscale Modelling of Aeronautical Components
[Manta Group, Italy](#)
- 74 Multi-Head Additive Manufacturing with Optimal HPC Thermal Stabilization
[Mikrotrvornica, Croatia](#)
- 76 Topology Optimization of Micro-Channel Heat Exchangers
[Aidro, Italy](#)

- 78 Multi-Phase Modelling of Nanofluid Hydronic System
[TCT, Italy](#)
- 80 HPC-based Hand Gesture Dataset Generation for Detection and Tracking
[Youbiquo srl, Italy](#)
- 82 Forecasting Reliability in Manufacturing
[KLS Ljubno, Slovenia](#)
- 84 Cloud-Based CFD Optimization of Magnetic Drive Pumps using HPC
[CDR Pompe, Italy](#)
- 86 Improvement of Graphene-Epoxy Based Composite Materials Production Through HPC
[Nanografi, Turkey](#)
- 88 HPC Simulation of Metal Powder Segregation in the Manufacturing of Cored Wire
[CEDIE, Spain](#)
- 90 High Performance Computing for Profile Extrusion
[Soprefa, Portugal](#)
- 92 Boosting CFD Simulation of Thermal Equipment for Food Processing
[TACORE, Spain](#)
- 94 A High-Fidelity Tool for the Optimal Design of Wind Assisted Propulsion Technology
[AYRO, France](#)
- 96 High-Performance Computing for High-Value Weather Forecasts
[Aslogic, Spain](#)
- 98 HPC Vessel Maintenance Optimization by Natural Language Assistance
[Figal Innova, Spain](#)



Accelerated Structural Design of Sustainable Aviation Projects

Organizations

ElevonX is an Unmanned Aerial Systems (UAS) producer and developer, focusing on UAS systems in the take-off range of 25 kilograms. **AFormX** is an SME that delivers composite airframes and provides simulations for sustainable aviation original equipment manufacturers (OEMs). **University of Maribor** provides knowledge for Finite Element Method (FEM) simulations and helps to deploy the workflow on HPC.



University of Maribor is part of the Slovenian NCC.



The Challenge

Sustainable electrically powered aircraft will look significantly different from aircraft of today. If the skin and the powertrain change, the structural frame also needs new designs and concepts.

AFormX identified the business opportunity to provide early structural analysis for the airframe - exploring a wide design space - to minimize risks of innovative structural concepts and provide green aviation start-ups with better structural designs.

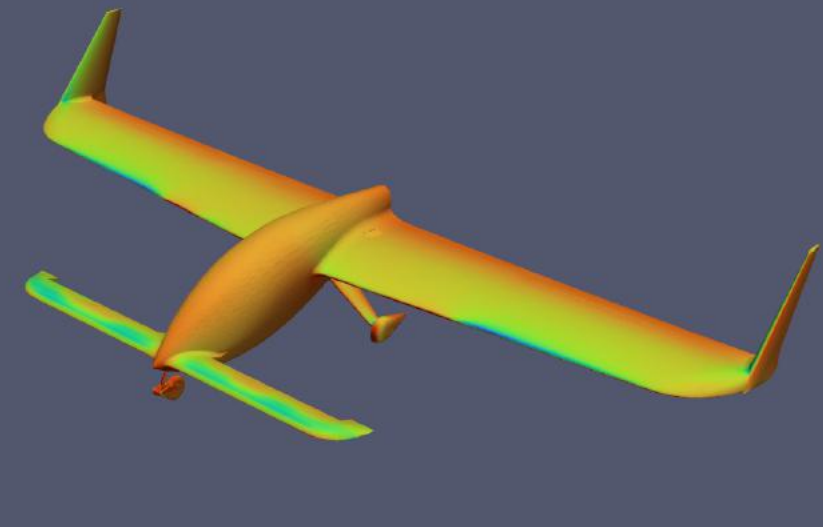

Industry Sector:
Aerospace
Technology used:
HPC, CFD & FEM
Simulation

Find out more



The Solution

The solution is an HPC-based workflow that will be offered as a service to the aviation market and can be used by OEMs and service providers. FEM simulations – using results from CFD simulations as boundary conditions – are performed for significantly different designs of the structural frame of the aircraft. The use of HPC makes it possible to efficiently explore a much wider design space: one design can be investigated in 20 hours of computing effort using 128 processors.

The Impact

The business impact for the SMEs AFormX and ElevonX is positive, increasing the level of their services and products. AFormX got into contact with many interested OEMs and already received tentative orders exceeding €200,000. The benefit for the OEM using the design tool scales in orders of magnitude: €1,000–€10,000–€100,000. €1,000 EUR is the cost for core hours. €10,000 will be the market price of the service. And €100,000 is the resulting cost saving for the OEM in the production run calculated per one unit (one aircraft). Lower cost results from better and more elegant architecture, reducing the material used and the build and assembly time. A lighter structure also creates a positive weight reduction spiral leading to less wing area, less drag, less power and lighter batteries. Moreover, this experiment is proof that smaller SMEs can adopt the use of HPC in their processes and that HPC computing hours are affordable. The workflow directly supports the green transition in aerospace, helping to design more efficient and cleaner aircraft and accelerating the electrification of aviation.

Benefits

- Tentative orders for the new service in the next 2 years at the present time exceed € 200,000.
- AFormX interacted with 7 new OEMs and deepened relationships with 2 existing OEM partners.
- Entry into the HPC aerospace field for the University of Maribor.

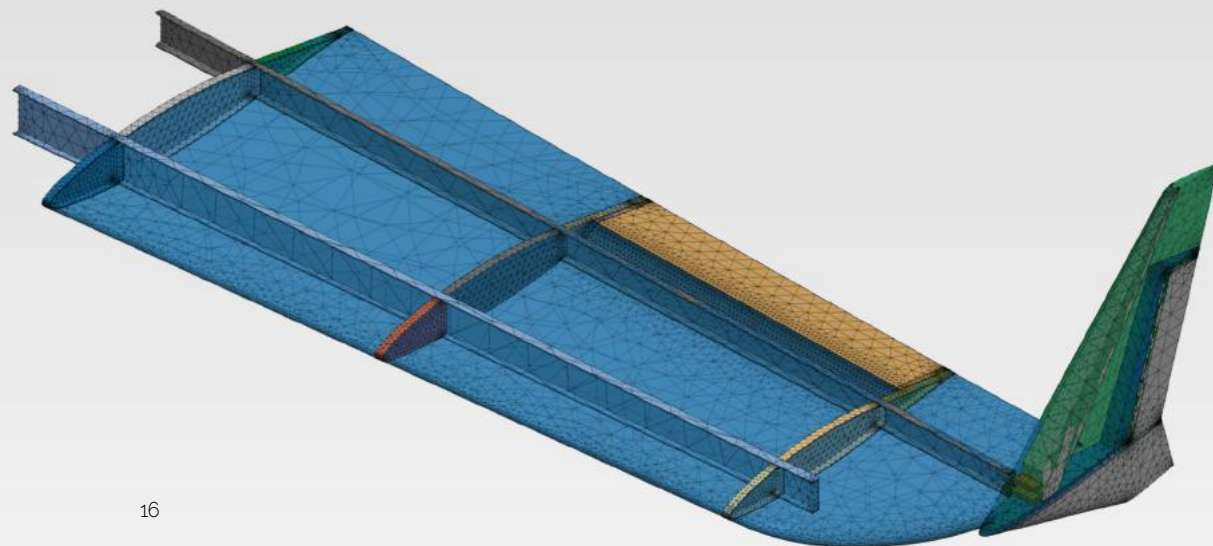



AI/ML Computer Vision for the Next Generation Poultry Farms

Organizations

Radinovic Company and **Meso-Promet-Franca** are well-recognised Montenegrin SMEs in the agri-food sector and poultry industry. **DigitalSmart** is a Montenegrin start-up SME targeting digital innovation and smart solutions based on AI. **DunavNET** is an ISV from Serbia and is an expert in implementing and integrating IoT/AI solutions in agriculture. **The University of Donja Gorica** is part of the NCC Montenegro and an HPC expert who provided support for experiment implementation and engagement of domain experts.



End Users



Technology Expert



ISV



HPC Expert



University of Donja Gorica is part of the Montenegrin NCC.

The Challenge

Monitoring chickens on large farms is highly labor-intensive and costly. Raising chicken to ensure animal well-being as well as humane food production means to closely monitor environmental conditions: measuring air temperature, air humidity, CO₂, and ammonia levels is required as a basis for successful production. AI and ML can be utilised to develop computer vision sensors that can monitor parameters. However, training, selecting, and calibrating the prediction models using only a standard computer was extremely slow and tedious.

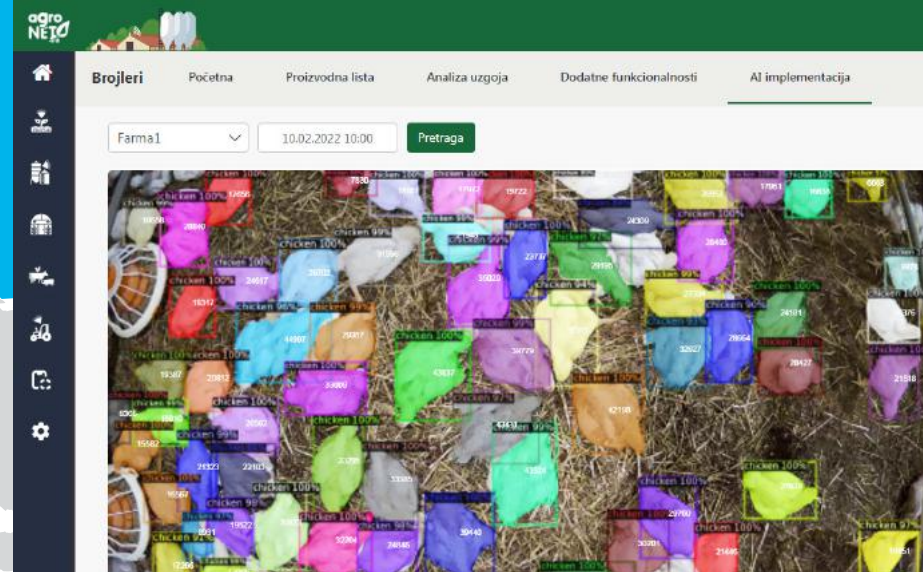
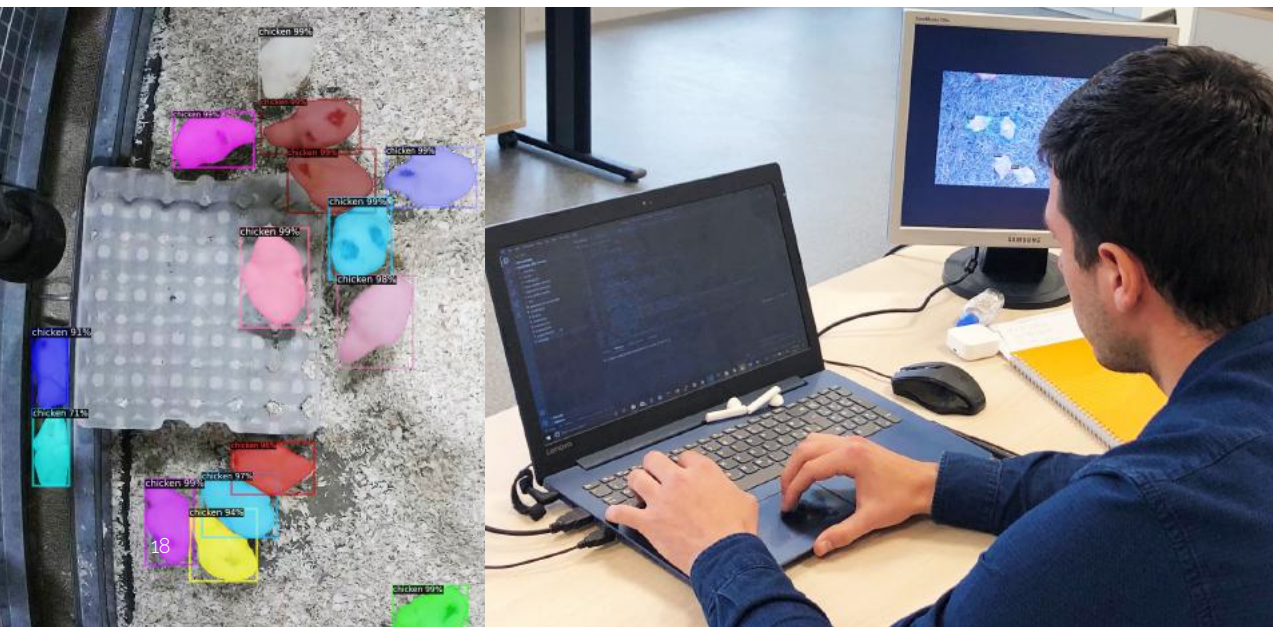

Industry Sector:
Agriculture
Technology used:
ML, Edge Computing

[Find out more](#)



The Solution

AI and ML algorithms were used to create prediction models, which could indicate the appearance of certain diseases. The involved organisations utilised HPC to efficiently apply DL to train and later calibrate prediction models. This led to the creation of a new type of precision agriculture sensor that combines cameras, edge computing, and an IoT platform. Models are calibrated for specific end-users and achieve an accuracy of over 90% for chicken detection and segmentation. Such IoT devices, enhanced with edge AI capabilities and new prediction models, represent new building blocks for advanced smart agriculture solutions for the poultry industry.

The Impact

The smart agriculture solution developed within this experiment could boost the productivity of poultry farms by reducing both manual labor costs and chicken mortality rates by about 10% each. For SME farms such as Radinovic Company and Meso-promet these savings could exceed hundreds of thousands of Euros annually. This is accomplished because assessing the weight of chickens in real-time increases the uniformity of the finished product and reduces the impact of stress on both the chickens and manual labor. Furthermore, real-time insight into poultry barns allow the improvement of disease management due to early detection. HPC provided the organisations DunavNET and DigitSmart with the technology needed to develop smart agriculture solutions quickly and efficiently using ML and computer vision, in this case for the needs of the poultry industry. The computer kit has become a part of their PoultryNET platform offering, and there is an opportunity to sell such components to third-party vendors active in the market of smart agriculture solutions.

Benefits

- Reduce both manual labor costs and chicken mortality rate by 10%.
- More than 10-fold speed-up of predictive model generation with HPC empowers SMEs to quickly commercialise customised solutions for customers.
- Quicker detection of disease or abnormalities led to improved animal well-being and better agrifood product quality.
- Better management of carcass disposal, dead chicken detection, and lower greenhouse gas emissions.



Improvement of Productivity in Aquaculture



Industry Sector:
Agriculture
Technology used:
HPC, AI, Edge
Computing

Organizations

Insuiña S.L. is a subsidiary of the Grupo Nueva Pescanova corporation, specialised in the cultivation of turbot.
Delcom Technologies is an SME and Data Analysis solutions provider employing Big Data and AI technologies.
Geneaqua is an SME providing genetic analysis solutions.
CESGA is a public HPC centre providing services for R&D.



Find out more



The Challenge

In aquaculture, fish growth and mortality are affected by highly volatile environmental conditions such as tides, temperature, salt levels, and water nutrients. This can result in losses to businesses of millions of Euros. Improving the ability of aquaculture farms to handle volatility and thereby increase productivity requires the centralised and rapid analysis of millions of productive, genetic, environmental, and biological data.

The Solution

HPC and Artificial Intelligence applied to data analytics empower the understanding of what influences fish behaviour, wellness, and growth, and allow aquaculture managers and operators to make data-driven decisions to prevent fish losses to achieve business stability or growth. HPC has enhanced ACUATIA, a DEICOM fish farm software, to incorporate data gathering, visualization, an expert system for custom AI model creation, and an online cloud management system to store, manage, and update data.

The Impact

The food industry is challenged to feed a growing world population of 8 billion. Precision aquaculture contributes significantly to a healthy human diet while improving animal welfare in the farms, reducing food waste, and avoiding overexploitation of marine resources. The business impact for aquaculture is direct and significant: the faster growth of the fish through optimized aquaculture management means that the appropriate sales-weight is reached 2 months early. This also has a positive environmental impact: the reduction of the sale age by 2 months leads to a proportional reduction in saltwater consumption, oxygen usage, and electricity consumption. Furthermore, because of the new accurate and faster growth predictions, the commercial department has more reliable information about the fish that they can offer to their customers and stock breaks (highly undesirable) are prevented. Data analysis service providers can improve predictive models, error results, and time reduction to producing new custom predictive tools. Data analysis service providers can adopt the approach taken in this experiment to enhance their service offerings through improved predictive capabilities and faster development of customized predictive tools.

Benefits

- 30% reduction in predictive model error through HPC.
- Shortening time to production in new user facilities or new procedures by 50%.
- Increasing business know-how for data-driven decisions for aquaculture farmers.
- 7% improvement in fish growth and a related 6.5% cost savings for the end user.





HPC-based Engineering Design for Control of Smoke in Subway Tunnels

Organizations

TECNOSISTEM is an SME operating in the engineering field that focuses on studying, planning, designing, supervising construction and providing technical service for complex infrastructures such as railways, subways, roads, stations, and ports. **ENGYS** is an SME that specializes in the development and provision of cost-effective open-source CFD software products and services for engineering analysis and design optimization. **CINECA** is the largest Italian HPC centre and cooperates with academia and industrial partners.



End User



ISV



HPC Provider



CINECA is part of the Italian NCC.



The Challenge

The design of smoke control systems and emergency strategies for fires in subway tunnels represents a very challenging task. The current design approach is sub-optimal and leads to increased personnel costs and design timelines due to lack of process automation and limited hardware resources for accurate physics modelling. Consequently, the costs for civil works, through oversized ventilation fans and risk factors for passengers, are increased.

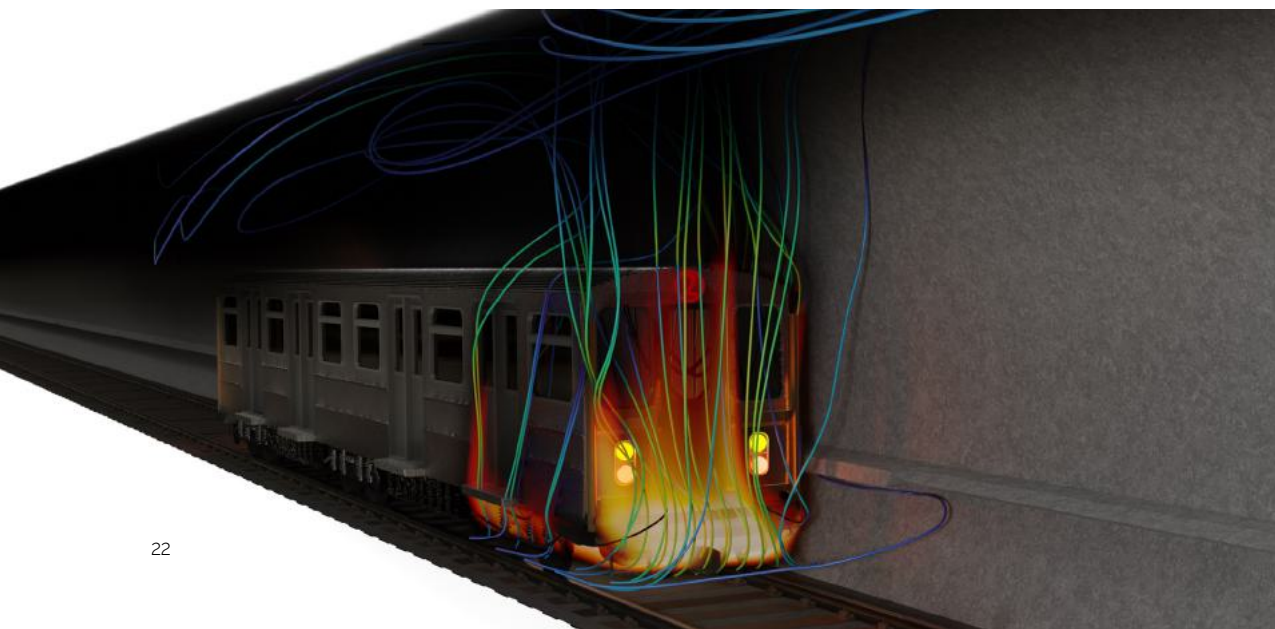

Industry Sector:
Civil engineering
Technology used:
**CFD Simulation,
HPC**

Find out more



The Solution

A unique framework leveraging HPC resources was created to simulate large CFD transient models of a complete subway node in the event of fire using a fully 3D approach, instead of the existing one based on approximate methods mostly using 1D tools. This innovative process was validated with a real metro line project, enabling the efficient design of smoke control strategies based on a detailed representation of the tenability and visibility field and a time-varying optimised control of the ventilation systems.

The Impact

The solution proposed by this experiment provides an immediate benefit to TECNOSISTEM by increasing market competitiveness via a significant internal cost saving due to the optimized design process. By extension, the newly HPC-based framework offers an attractive solution for TECNOSISTEM customers including construction companies as well as communities, since the new design methodology allows for a substantial downsizing of ventilation fans and silencers, thus reducing the excavation volumes and civil work-related costs. ENGYS plans to integrate the HPC interface developed for the experiment into the proprietary software HELYX and will target any potential SME operating in the rail construction and engineering sector to provide a unique design framework via high-fidelity CFD. Finally, the adoption of the newly developed HPC-based methodology will have a societal impact in terms of increased safety, since a safer emergency design will result in a considerable reduction of risk factors for passengers in underground mass transport.

Benefits

- Internal cost saving for TECNOSISTEM between 7% and 15% for a typical subway line design.
- 4-7% turnover increase for TECNOSISTEM in five years via design efficiency and increasingly competitive offer.
- New market segments where ENGYS can offer an HPC-based solution for fire safety engineering.
- Savings in construction costs which can range from €3M to €9M for a typical subway line.



Cloud-Based CFD for Urban Microclimate Assessment and Architectural Planning

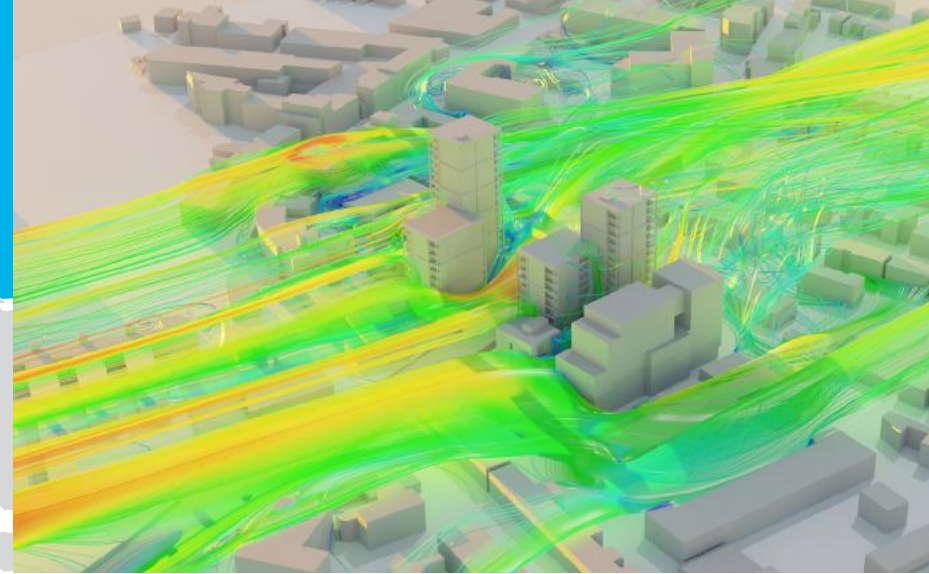

Industry Sector:
Civil engineering
Technology used:
**HPC, CFD
Simulation**

Organizations

SoftSim is a Bulgarian SME that has been operating successfully in the Urban Physics Modelling (UPM) sector and the Architecture, Engineering and Construction (AEC) industry for the last 8 years. **ENGYS Ltd.** is an SME specializing in the development of CFD software products and services for engineering analysis and design optimization. **HLRS** is one of the three national supercomputing centres in Germany.



HLRS is part of the German NCC.



The Challenge

SoftSim offers a broad spectrum of Urban Physics Modelling (UPM) solutions to investigate urban microclimates, e.g. wind loading of structures, relying on high-fidelity CFD methodologies. Increasing regulatory standards demands investigating many different scenarios, e.g. different wind speeds, with accurate simulations for each microclimatic study. SoftSim needs a viable way to realize resources (HPC and skilled staff) to meet those demands.

The Solution

A comprehensive UPM infrastructure, based on ENGYS's main product HELYX®, was developed and offers seamless access to HLRS's system through a Graphical User Interface. By employing HPC resources on-demand, SoftSim can now conduct high-fidelity CFD experiments on finer computational grids and with fast turnaround times, while simultaneously saving the cost of financing in-house computing systems and streamlining its computational analysis procedures.

The Impact

Being able to offer a wider range of more sophisticated and reliable services by leveraging HELYX and on-demand HPC has enabled SoftSim to bid for larger-scale, more lucrative contracts through which a substantial revenue growth is expected. By reducing unit costs, the new process chain has led to a notable reduction in the overall operational expenses, freeing up company profits for re-investment. Automated workflows facilitate the completion of complex engineering tasks by reducing the level of required expertise. As a result, SoftSim has now established a more sustainable environment in which the company can meet the industry's demands, expand its staff, scale from low-cost outsourcing to a high-value provider and raise its profile within the UPM market. Through delivering more cost-effective and comprehensive CFD solutions tailored for UPM applications, ENGYS has expanded its portfolio within the AEC sector. An increase in Software-as-a-Service (SaaS) revenue is expected to emerge from offering on-demand HPC services through the HELYX/HLRS interface.

Benefits

- SoftSim expects 300% increased revenue in the next 4 years (annualised approx. €400,000).
- Reduced unit costs: approximately 25% reduction in analyst time for SoftSim.
- ENGYS expects an 80% increase in SaaS revenue over 3 years (annualised €300,000).
- Increase in ENGYS's UPM customer base from 18 to 30 (annualised revenue increase of €550,000).

Find out more

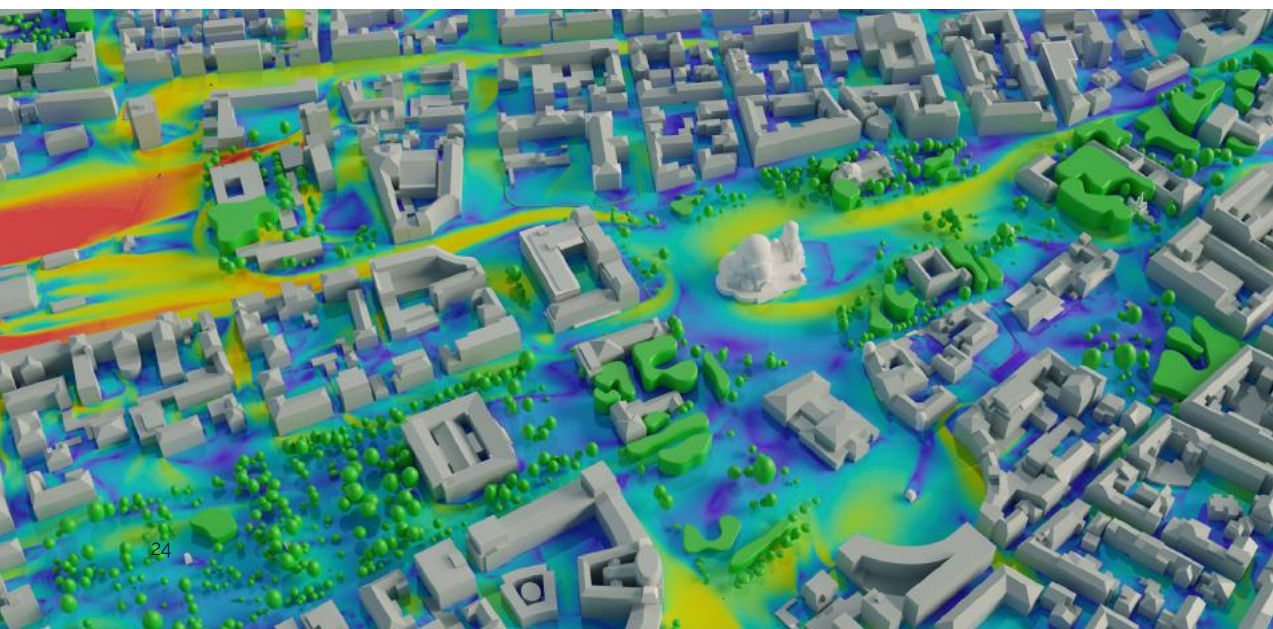



Accessible Acoustic Simulation Platform to Create Better Sound Experiences

Organizations

Trivium is an Icelandic acoustic consultancy SME focusing on acoustic simulation-aided design for buildings, noise mapping, and room acoustic measurements. **Treble Technologies** is an Icelandic start-up that develops acoustic simulation software. Treble is an industrial cooperation partner of the Icelandic NCC. **DTU Compute - of The technical university of Denmark** - is a leading institute in HPC and simulation methods.



DTU Compute is part of the Danish NCC.

The Challenge

Most room acoustic simulation tools are based on simplifying approximations. These can be acceptable for large rooms. But for small ones, this leads to more design iterations, overuse of expensive acoustic treatments, and frustrated customers. For better results, one needs to simulate the acoustics by solving the true wave equation. This is possible with the Finite element method (FEM) but has not been feasible due to long simulation times.

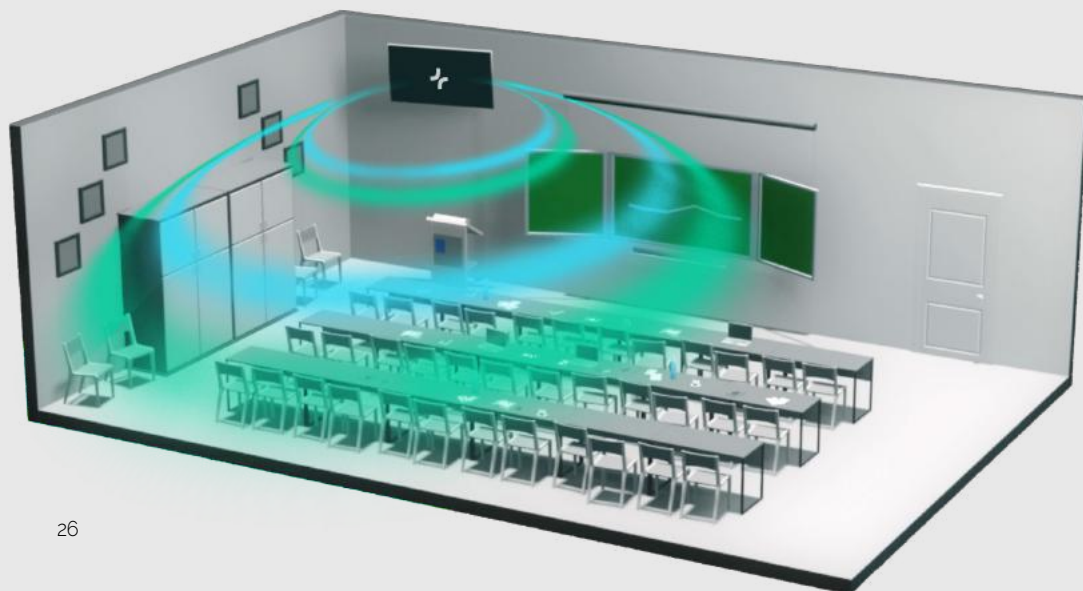

Industry Sector:
Civil engineering
Technology used:
**HPC, FEM
Simulations**

[Find out more](#)



The Solution

The solution developed uses advanced FEM algorithms well suited for HPC and multi-GPUs. The tool gives Trivium cloud access to fast and accurate wave-based sound simulations from a web browser, with an optimised workflow, easy-to-use interface, and connections to leading 3D modelling tools. With HPC, the simulation time can be reduced to minutes - hours instead of days - weeks, facilitating the possibility of iterative designs and bulk simulations.

The Impact

The improved accuracy will give Trivium an advantage when it comes to fast and accurate acoustic designs, fewer design iterations and better results for the customer. The modern user interface and workflow contribute to reducing the time required to finish a project by 30% compared to previously available solutions.

The results viewer and auralizer (a feature to realistically listen to simulations) were optimised during the experiment to best fit the needs of Trivium. These parts of the tool contributed significantly to the time reduction of a project since a large amount of time often goes into collecting and presenting results to the customer in a clear way.

The experiment also resulted in new know-how on the acoustic treatment of low-frequency noise. This part of audible noise is very important in all acoustical designs as it can be extremely disturbing. The tool leads to better-informed decisions when tackling the problem of low-frequency noise, which is estimated to improve customer satisfaction by 50% since low-frequency disturbance is the most common customer complaint.

Benefits

- The improved workflow will boost the productivity of Trivium for each employee by an estimated 25-50%.
- The software is estimated to increase Trivium's turnover by up to €15,000 per worker per year.
- The software can lead to time savings of up to 30% due to improved workflow and immediate feedback.
- The projected revenue for Treble Technologies from software sales exceeds €1M for 2024.



Leveraging HPC for AI and Deep Learning Powered Solutions for Asset Management

Organizations

AXYON AI is an Italian fintech SME on a mission to bring AI-powered predictive value to the investment management industry.

UNIMORE - AlmageLab is a research laboratory of the Dipartimento di Ingegneria "Enzo Ferrari" at the University of Modena and Reggio Emilia.

CINECA is the largest Italian HPC centre and cooperates with academia and industrial partners.



End User

Research Centre

HPC Centre & Provider



CINECA is part of the Italian NCC.



The Challenge

Optimising financial portfolios composed of assets like stocks, bonds, and indices with respect to revenue and risk is a core task in the financial industry. Banks, asset managers, and hedge funds face a continually increasing amount of data that needs to be considered for optimal results. AI-based methods offer a predictive power superior to commonly used purely quantitative approaches and represent a tremendous opportunity for highly innovative fintech companies to provide such solutions to the finance industry and bring portfolio risk assessment to a new level.



Industry Sector:
E-Commerce
Technology used:
HPC, AI, DL, ML

Find out more



The Solution

The development of AI/DL-based models to support asset management brings rigorousness and automation to the models that guide better investment choices and support the creation of risk management tools. These tools in turn contribute to the entire system's stability and reduce investors' risks. With the HPC infrastructure boosting the computation scalability of the ML platform, Axyon IRIS® was further developed to support investment strategies with over 1,000 financial assets.

The Impact

With the enhanced offering developed during the experiment, Axyon AI can expand its market reach to a wider array of customers, especially SME customers that need a complete, end-to-end solution. In detail, the following main business impacts for Axyon AI were achieved:

- Increased computational scalability of the company's ML platform allowed Axyon AI to train larger ML models on larger datasets (1 order of magnitude) and lower costs (approximately 25% of cost savings).
- Enhanced Axyon IRIS® risk management features for end-to-end portfolio construction resulted in a larger market target (approx. 150% increase of the serviceable obtainable market).
- Improved adaptability of Axyon IRIS® forecasting models decreased the time needed for the model retraining by around 30%, an important improvement in a fast-changing market scenario.

Benefits

- Approximately 25% of product cost savings.
- Ability to train AI models with over 1,000 financial assets instead of 100, resulting in a larger approachable market.
- Due to the enhanced product features, improved company positioning in the market.
- generation of new sales opportunities (a 30% increase in leads generation expected) and contributing to the completion of a €1.6m fundraising round in July 2022.



Market Innovation Sourcing

Organizations

Parsionate GmbH is a consulting company in the field of digitalization, data analytics/science and data management. **Price Intelligence GmbH** focuses on the collection and analysis of e-commerce market data and resulting actions, providing SMEs with data analytics for automated decision-making. **German Top Secure** provides industry-leading hardware infrastructures and software PaaS to organizations. **HLRS, University of Stuttgart** is one of the three national supercomputing centres in Germany. **SICOS BW** supports SMEs in accessing simulation and HPC as well as big data and smart data topics.



End User Domain Expert HPC Providers Scientific Collaborator



HLRS & SICOS BW are part of the German NCC.



The Challenge

The E-commerce market is growing rapidly. It is becoming increasingly complex to decide on the right assortment and pricing of products and to identify innovations, trends, and counterfeits. In the past, this comparison was done using unique identifiers like the EAN (European Article Number) or Manufacturer Part Number. Since many platforms have disabled the EAN or MPN search functions, a new product-matching method had to be found. For this purpose, image or textual data from product descriptions could be used, but the combination of both in a single search approach would enable the creation of a more reliable and powerful model for product identification and comparison.

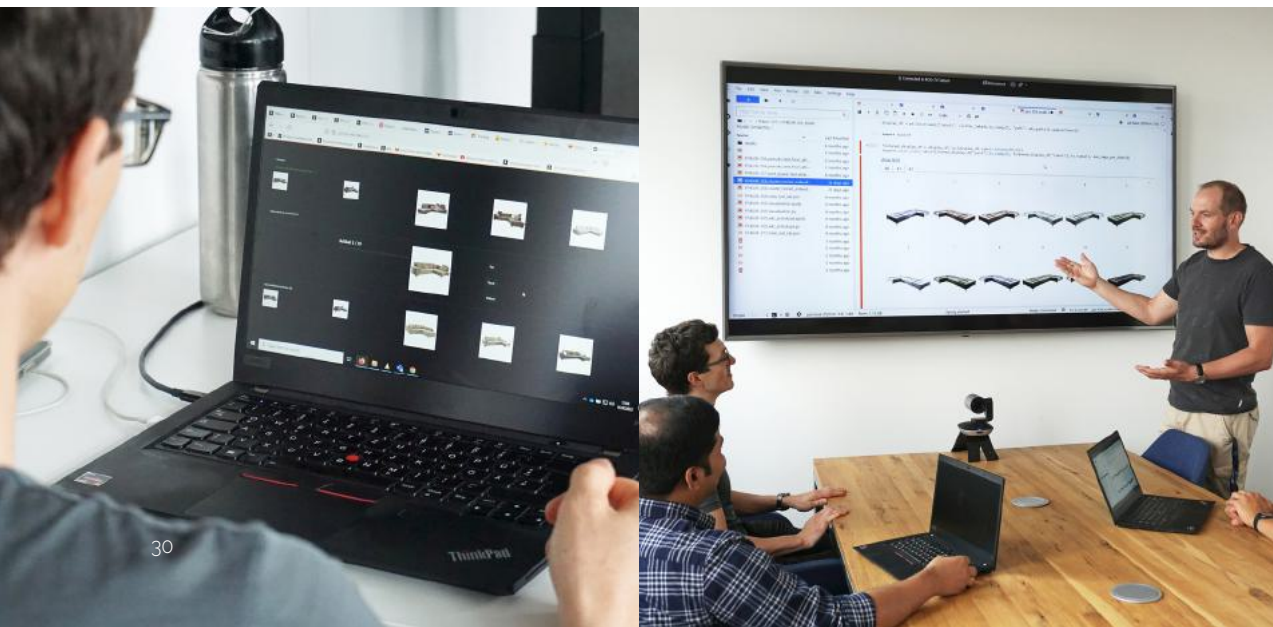

Industry Sector:
E-Commerce
Technology used:
HPC, AI, ML

Find out more



The Solution

Pre-processing was done to transform product data into so-called embedding vectors. The key tool for computing embedding vectors is neural networks, and pre-trained networks based on generic data are an important and valuable building block. Price Intelligence created pre-trained networks for both image and textual data in isolation that could be employed to implement a synthesized algorithmic approach to build networks pre-trained with a combination of all data. For customers, pre-built networks will subsequently be customised using the customer's product data and also related product data to generate better embedding vectors, fitted to the specific use cases, and thereby producing better matching results.

The Impact

The newly created matching service decisively expands the existing software of Price Intelligence and will be available to over 100 European manufacturers and retailers to help them optimize their pricing and, as an example of a new feature, even optimize their portfolio. The matching service is already being used productively by two retail customers within a web store and call centre to optimize their suggestion system for alternative products. Price Intelligence has already identified many other potential customers from various industries. The knowledge gathered in the experiment can be used to create other new services such as assortment analysis, detection of product trends, or detection of counterfeit products using similar techniques. Due to the wide range of projects in which the two partners Price Intelligence and Parsionate are involved, many companies in Europe will benefit from the capabilities developed in the experiment.

Benefits

- End customers from retail and manufacturing use over 70% less time when searching and comparing items on the internet.
- With the new product matching service in the Price Intelligence software, an increase in sales of up to 30% is expected.
- The newly developed matching service for finding similar products in an assortment has already led to new sales at Parsionate.



Robust Power System Maintenance Planning via Stochastic Optimization and HPC

Organizations

Artelys is a French SME specializing in applying data science, artificial intelligence, mathematical modelling, and numerical optimisation to the analysis of power systems. **INRIA-Aviz Team** is a worldwide renowned research group specializing in big and unstructured data visualization. INRIA also provides the HPC resources for this project.



Industry Sector:
Energy
Technology used:
HPC, Monte Carlo
Simulations

Find out more



End User



HPC & Technology Provider



The Challenge

Shutting down a power plant or transmission line for maintenance likely means having to rely on more expensive energy sources or external energy providers. Moreover, as the installed capacities of renewable energy sources grow and electric mobility options are deployed, the overall system becomes more subject to uncertainties. As such it is of prime interest to develop tools to ensure that maintenance plans are prepared for a number of scenarios.

The Solution

Solving the problem required creating a representative data set for the European power system. Massive scenarios were simulated and optimised. For every candidate maintenance plan, various plausible, yet unknown scenarios were generated. The results of simulations were combined to compute KPIs for maintenance plans. During computation, the KPIs were fed back into an optimisation model which computed the next candidate maintenance plan. This process was repeated until all potential plans in a greedy approach were exhausted or until convergence was achieved in the case of local optimisation.

The Impact

This approach will help power producers and transmission system operators schedule their maintenance in a manner that is resilient to uncertainties. By finding optimal maintenance timing, they will reduce the risk of having to resort to external market players or minimize this cost and reduce the risk of potential demand curtailment situations. Optimal scheduling of maintenance can prevent the need to resort to more polluting assets to compensate for the limited availability of other power generation assets. Artelys gained the ability to conduct quantitative prospective studies on behalf of its clients for a large number of scenarios that cover uncertainties. It is expected that the results will contribute to as much as €4 million in revenue in the upcoming years through performing this new type of prospective study. Artelys bundle the HPC-based optimisation with their portfolio of optimisation software available to more advanced customers. This work also has societal impacts as it will help key players make better use of the power system, which in the end sums up to better usage of renewable energy generation resources and a lower cost of electricity.

Benefits

- Estimated additional sales of up to €4 million over the next 5 years.
- HPC-based computational tools enable 3 quantitative studies per year (previously infeasible) and accelerate and improve up to 5 other studies per year.
- Improved calculation capabilities in Artelys software for experienced users.

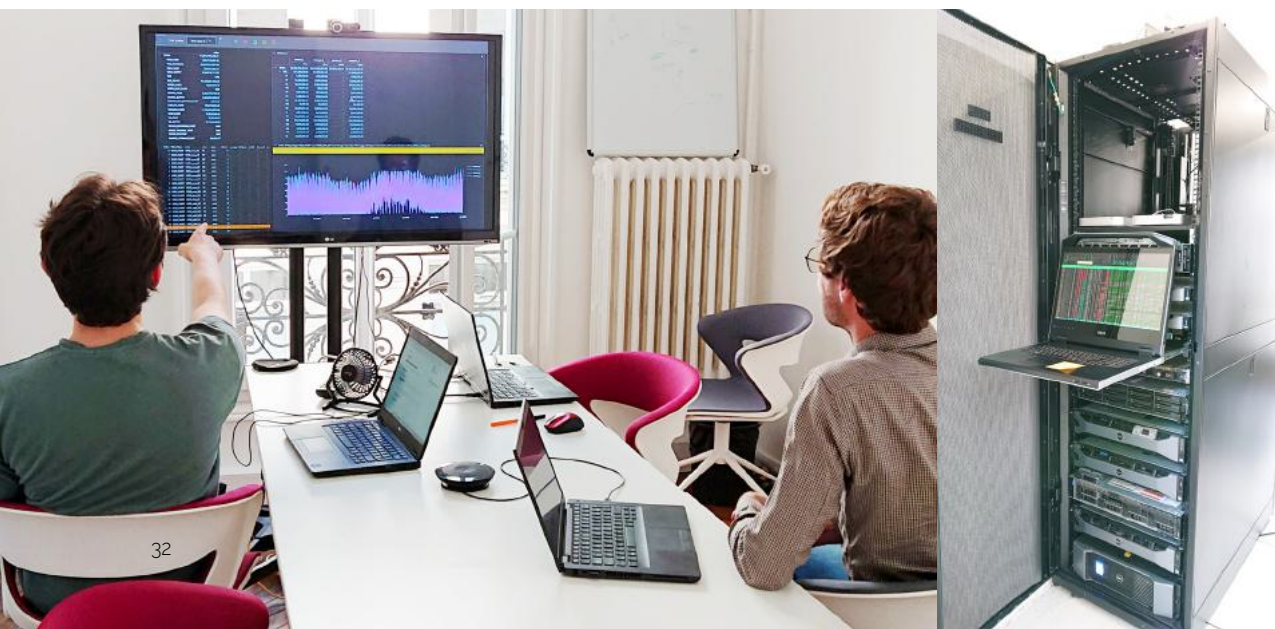



Optimising Performance of Air-Cooled Condensers Using Wind Shields

Organizations

Galebreaker Ltd, an SME located in the UK, is recognised worldwide for manufacturing fabric-based products which guard against the elements in the industrial and agriculture sectors.

Ergon Research srl is an Italian SME that provides consulting and research optimisation using advanced simulation tools in the thermo-fluid-dynamics field.

CINECA is the largest Italian HPC centre and cooperates with academia and industrial partners.



End User



Technology Expert



HPC Provider



CINECA is part of the Italian NCC.



The Challenge

The performance of Air-Cooled Condensers used in power generation is substantially affected by crosswinds, which significantly impact the efficiency of the power generation plant. Windshields are used to optimize the system, but their size, placement, and porosity can be subject to many local factors. In the design phase of the windshields, a more effective, accurate, and quicker way of predicting the associated performance benefits is required.

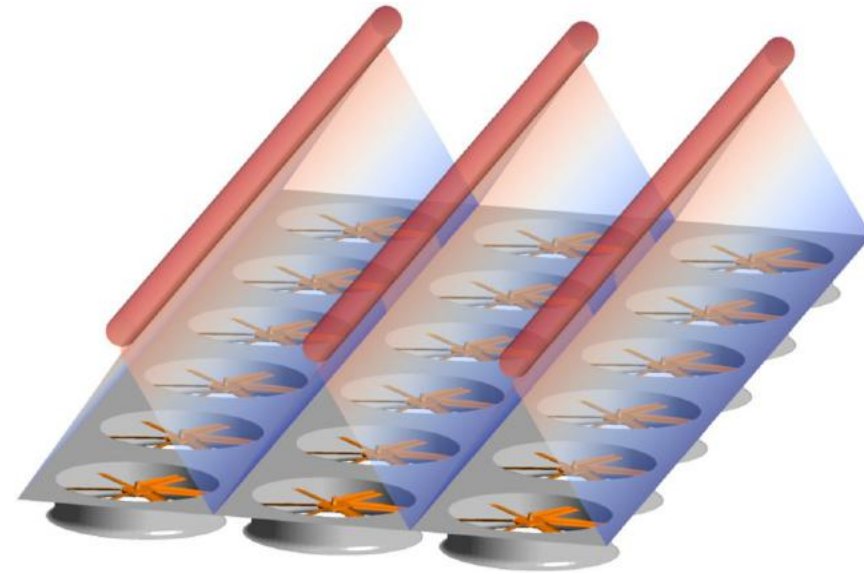
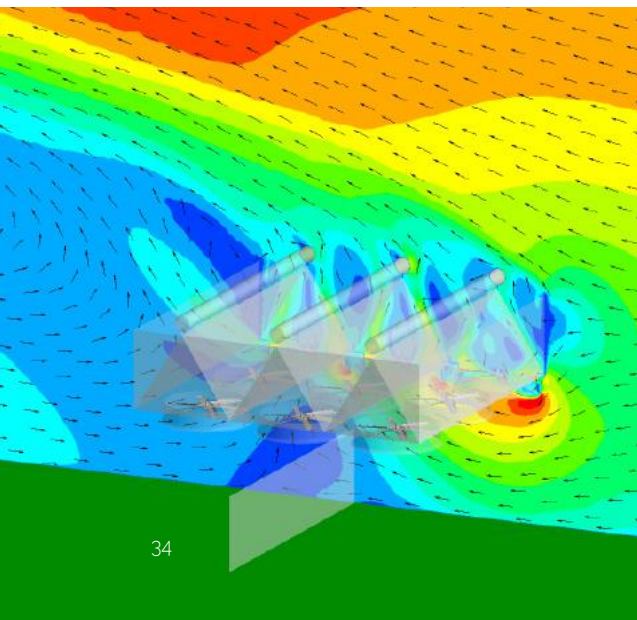

Industry Sector:
Energy
Technology used:
HPC, CFD

Find out more



The Solution

Using a high-fidelity CFD model and extensive HPC resources, it was possible to identify windshield layouts able to reduce the wind losses by 85% and to provide a significant reduction in the oscillating blade load. Results from these extensive computations have been used to create a digital twin of the power plant for real time performance predictions, which in turn estimate yearly savings for a given annual weather forecast coupled with the local cost of energy.

The Impact

GALEBREAKER and ERGON RESEARCH have built a reputation for supplying reliable products that reduce the detrimental effects of wind on ACCs, with tangible improvements in the environmental impact of the energy sector. However, potential customers need credible tools for impact estimates. The experiment outcomes (more trustworthy guidelines for the design of windshield, the availability of a digital twin, and the implementation of a payback calculator) address this need by enabling the accurate estimation of the return on investment for windshield installation.

Not only will GALEBREAKER and ERGON RESEARCH see increased (50% over 3 years) business from this experiment, but significant efficiency improvements will also be achieved in the power generation plants, resulting in reduced carbon footprints. Through the reduction in maintenance issues of fan blades and gearboxes, extended lifetime and availability are expected, and the resulting less frequent downtime of the power plants will mean more reliable power generation.

Benefits

- The use of HPC reduces the time for delivery of a windshield layout optimisation analysis by 50%.
- High-fidelity ACC performance prediction provides higher credibility for expanding the customer base.
- Dynamic fan blade loading can be analysed indicating savings on gearbox and blade maintenance.
- The digital twin of the plant can quickly estimate the yearly savings thanks to windshields.



Accelerating CFD Simulation of Immersive Battery Cooling

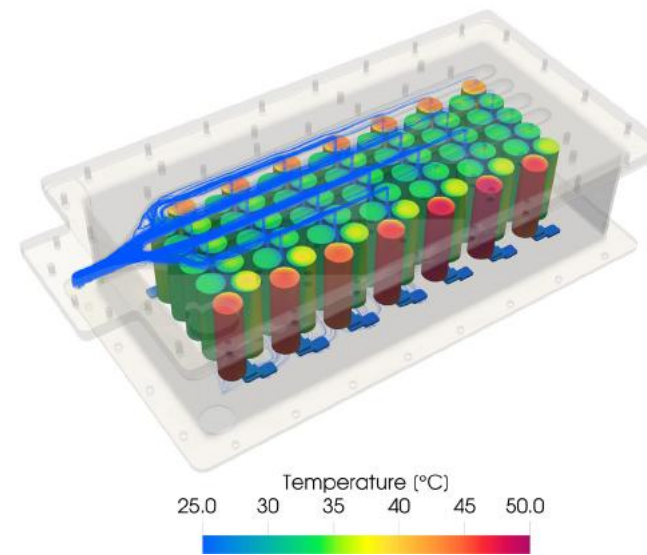

Industry Sector:
Energy
Technology used:
HPC, CFD
Simulation

Organizations

Wamtechnik is an SME focused on the development and manufacturing of battery packs. Wamtechnik was the first company in Europe to develop batteries for an electric bus (Solaris Urbino Electric 8, 9). **QuickerSim Automotive** is an engineering & simulation software development SME developing e-mobility applications. QuickerSim Automotive offers Q-Bat – a thermal simulation software for battery packs.



Find out more



End User



Simulations Expert & ISV



The Challenge

The development of immersive cooling battery packs typically relies on prototyping and experimental testing, which is both time- and resource-intensive. While CFD numerical simulation can accelerate the design process, the use of general-purpose CFD codes is also significantly demanding of both expertise and computing resources, especially with transient phenomena and temperature-dependent material properties. Pre-processing (including meshing) for complex geometries is a further major challenge.

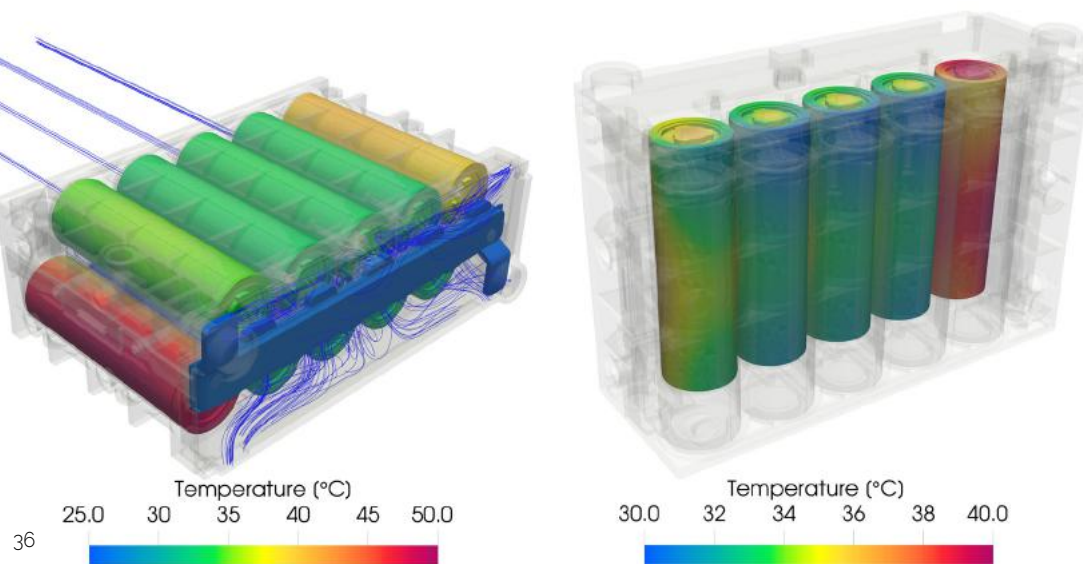

36

The Solution

Building on QuickerSim's MATLAB-based software, Q-Bat, a dedicated simulation workflow was developed for battery packs with immersive cooling. This exploits fluid flow simulations with the OpenFOAM library executed on HPC systems (via an automated case generation tool) and the training of a data-driven forced convection model. This enables battery pack design specialists, without CFD expertise, to investigate the heat transfer within the coolant and between coolant and battery pack components.

The Impact

For Wamtechnik, the developed simulation workflow can save considerable time and resources. Due to the manufacturing and testing of several prototypes in every design cycle, the total development cost amounts to approx. €60,000/kWh. The developed simulation workflow enables Wamtechnik to test various designs concurrently, subsequently reducing the number of manufactured prototypes to only 1-3 for every design cycle. This allows them to reduce the development costs to approx. €48,000/kWh, and shorten the development time by as much as 30%. Fewer prototypes also mean a smaller environmental footprint. For QuickerSim Automotive, the development of the immersive cooling workflow opens new revenue streams, both in software license fees and consultancy services. In the past, sales were limited to companies developing battery packs with cooling plates or passive cooling. The new features will aid the adoption of Q-Bat by OEMs, and the e-mobility market in general, where the development of immersive cooling solutions for applications such as fast charging is growing rapidly.

Benefits

- Development cost of battery packs reduced from €60,000/kWh to €48,000/kWh.
- Testing a design modification done in a couple of days, (compared to 1-2 weeks) if all components are manufactured in-house.
- A 2-year design cycle can be shortened by up to 7 months while decreasing the number of battery prototypes.

37



Beyond Molecular Dynamics Simulations and Analysis for Battery Materials Development

Organizations

Enerpoly is an energy storage technology SME pioneering rechargeable zinc-ion battery chemistry. **Compular** is an SME developing HPC software for simulating and analysing molecular dynamics in material development projects. **Chalmers Industriteknik** is a non-profit foundation offering academic expertise within the areas of materials, energy, and digitalization. **ENCCS** is an initiative aiming to provide a unified HPC know-how hub for academia, industry, and the public sector.



End User



ISV



Technology Expert



HPC Expert



ENCCS is part of the Swedish NCC. 

The Challenge

Enerpoly, developing new battery solutions based on zinc-ion technology, faces serious problems such as irreversible loss of charge or material. To better understand the relevant properties of electrolytes without expensive and time-consuming lab tests, Enerpoly would like to use Compular's in-house simulation tool based on a novel and patent-pending combination of molecular dynamics (MD) simulations and trajectory analysis of charged particles, not yet available as a product.

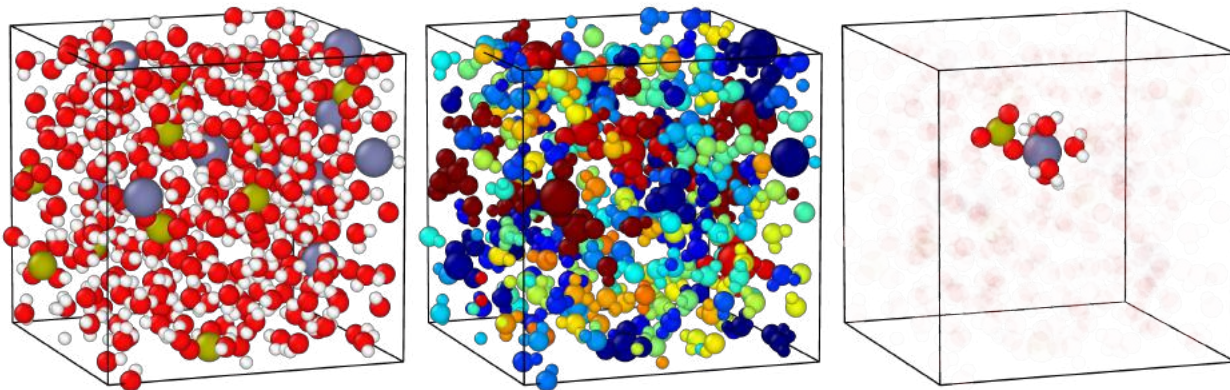

Industry Sector:
Energy
Technology used:
HPC, AI, Molecular
Dynamics
Simulations

[Find out more](#)



The Solution

Compular's software libraries were transformed into the pay-on-demand product "CHAMPION". It analyses the results of external MD simulations running on HPC to determine bonds in particle trajectories and detect molecular structures in the electrolyte that're relevant to battery chemistry performance. The workflow was validated on Enerpoly's existing zinc-ion battery system, ensuring correct results and trustworthiness for future use on unknown, novel material combinations and battery systems.

The Impact

As the first user of Compular's newly developed in-silico framework, Enerpoly now has the tools to cut down battery material R&D time and lab testing costs significantly. By running the MD simulations themselves, they better understand how different compositions and conditions lead to desired material properties. Thus, Enerpoly is able to shorten time-to-market for novel, better-performing and more affordable batteries, which is essential for the company's competitiveness in this fast-moving field. Compular's potentially game-changing technology was transformed into a software product, CHAMPION, sold through a new competitive SaaS pay-per-HPC-analysis business model. This opens new market opportunities in the dynamic battery sector, with the potential for expanding to other markets (e.g. composites) in the next 3-5 years. Furthermore, this experiment and growing interest from the battery industry has already secured 3 new paying customers with the full European market launch expected in 2023. Consequently, the company grew from 3 to 7 employees with further hires anticipated in 2023.

Benefits

- Enerpoly can run millions of experiments in silico compared to 10 experiments per month in a lab.
- Enerpoly reduced lab experiments by 20% and related costs by 20-30% resulting in a 5x- 10x return on investment.
- Estimated 20-40% faster time-to-market for Enerpoly batteries.
- New SaaS business model: Compular already gained 3 new customers and hired 4 new employees.



Optimal CO2 Capture and Utilization Plant Design Through HPC

Organizations

Y Squared is a Greek SME providing consulting services in the design of industrial chemical process systems, especially CO2 capture and utilization systems.

CERTH is one of the top research centers in Greece and Europe, expert in HPC and CO2 capture and utilization technologies.

Yotta Advanced Computing is a Croatian Hi-Tech SME, HPC expert and provider.



End User



Technology Expert

CERTH
CENTRE FOR
RESEARCH & TECHNOLOGY
HELLAS

HPC Provider



Centre for Research and Technology Hellas is part of the Greek NCC.



The Challenge

One important part of mitigating greenhouse gas emissions is the availability of low-cost CO2 capture and utilization (CCU) processes for intensely emitting industries like the quicklime and cement sectors. Current commercial tools for designing CCU processes have limitations that Y Squared would like to overcome with HPC, thereby increasing the searchable design and operating spaces, leading to more robust and cost-effective CCU systems.



Industry Sector:
Energy
Technology used:
HPC

Find out more



The Solution

The experiment has resulted in computational tools that combine algorithms for chemical process design and control with approximate computing and parallelization techniques. With the new tools, the discrete combination parameter space has increased by three orders of magnitude. The ability to solve the CCU problems simultaneously has reaped significant benefits compared to that of a sequential design approach. The computational time to obtain the optimal design has decreased by a factor of 50.

The Impact

Y Squared is engaged in the design of CCU processes, primarily serving as a consultant for the cement and quicklime industries. The demand for CCU plants is expected to rise sharply due to the strict CO2 regulations set internationally. The improved software provides Y Squared with a competitive advantage and market expansion opportunities in Greece and other European countries. The simultaneous design approach used in CCU resulted in a 6.5% lower cost per ton of calcium carbonate nanoparticles produced than the best, pre-project, sequential case. Due to the speed up achieved through employing HPC, the company engineers managed to increase their efficiency and produce improved designs in a short amount of time. This allows Y Squared to take on more clients simultaneously and provide them with its customised and specialised services. The increased workload is expected to result in the creation of several job vacancies, as well as internship opportunities for young trainees to get exposure to chemical process design and modelling, advanced computing techniques, and HPC.

Benefits

- 6.5% cost reduction of calcium carbonate nanoparticles makes CCU more profitable.
- 1000x larger design spaces and 50x faster optimisation result give Y Squared a competitive edge.
- 30% increase in revenue from design studies expected over the next 3 years.



High-Fidelity Modelling of a Hydrogen-Fired Industrial Combustor

Organizations

EM Combustion is a Spanish SME that develops customized solutions for industrial combustion systems. The application fields include energy, oil and gas, steel and metal industries. **Barcelona Supercomputing Centre (BSC)** is the National supercomputing facility in Spain. The BSC team involved in the Propulsion Technologies Group develops computational models for power and propulsion applications.



End User



HPC Provider & Expert



Barcelona Supercomputing Center is part of the Spanish NCC.



The Challenge

EM Combustion (EMC) develops versatile burners for energy plants, capable of operating with various fuels. The EU's commitment to achieving net-zero greenhouse gas emissions by 2050 drives prioritising low-carbon technologies. Green hydrogen and hydrogen-enriched fuels offer the potential for clean, efficient power generation. But this transition poses challenges, especially for SMEs in the sector. To stay competitive, EMC needs targeted and efficient digitalization.

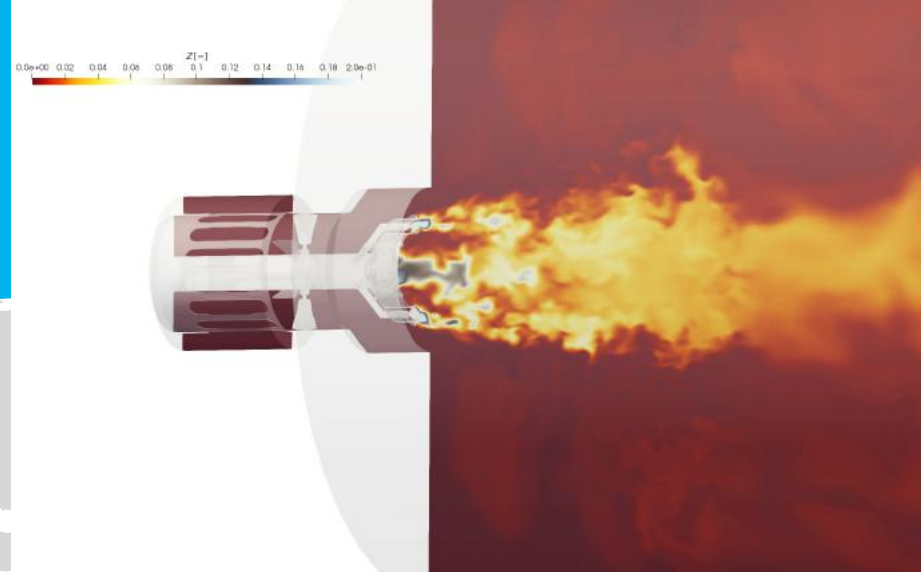
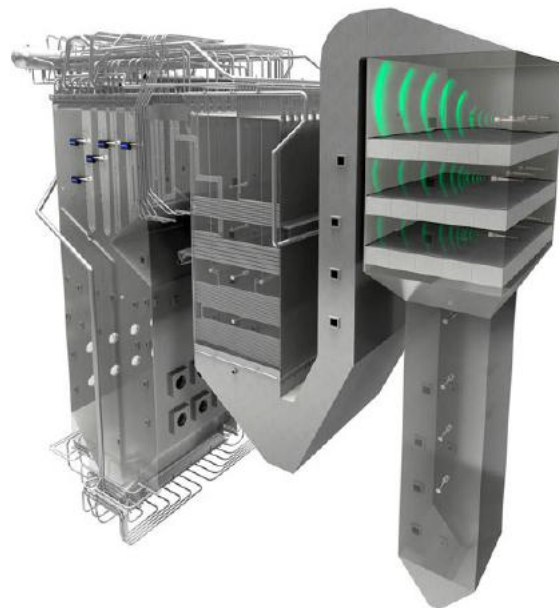
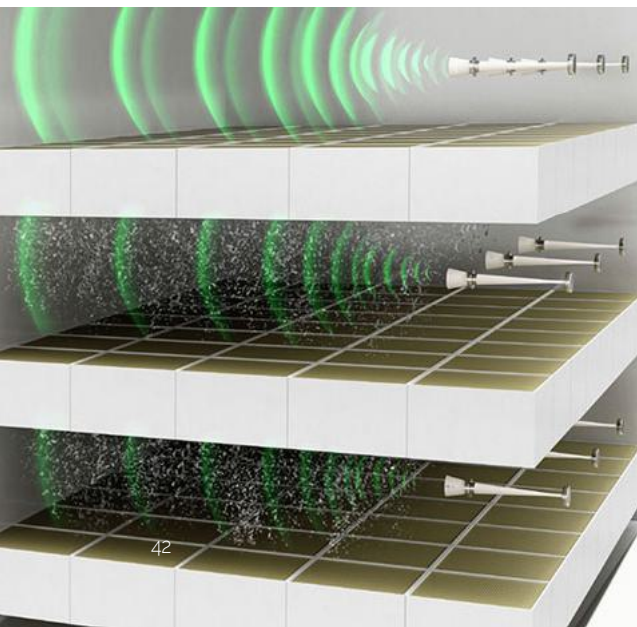

Industry Sector:
Energy
Technology used:
HPC, CFD
Simulation

Find out more



The Solution

The experiment developed a platform for the simulation of combustion dynamics, pollutant formation, and burner operability for hydrogen-enriched fuels in industrial combustors. This platform is integrated into EMC's product design cycle. The experiment combines physical tests and high-fidelity simulations, with the goal of deploying low-carbon power generation while reducing the design cycle duration and costs. HPC is essential as combustion simulations are computationally intense.

The Impact

EMC can benefit from a computational platform for virtual testing of industrial combustors using HPC via the following business impacts:

- EMC will save significant costs associated with traditional physical testing. It reduces the need for expensive prototypes, testing equipment, and specialised personnel. The estimate of savings in the design cycle of a new combustor is around €50,000.
- With virtual testing, EMC can accelerate the development of new industrial combustors, achieve faster time-to-market, gain a competitive advantage, and increase its market share. Estimations show that around 4 to 6 months of testing time could be saved.
- Enhanced innovation: The computational platform can allow EMC to test new and innovative designs of industrial combustors that may not have been feasible with traditional testing methods, reducing fossil consumptions and emissions.

Benefits

- Shortening time-to-production and time-to-market by 20%.
- Gaining hydrogen technology know-how, reducing maintenance costs by 25% with numerical simulation.
- Expanding EMC's consultancy offer, generating €100K in the first year, increasing turnover by 5%.
- Starting the digitalization of burner design, reducing design costs by 30% and worker costs by 5%.



HPC-Based Navigation System for Marine Litter Hunting

Organizations

Green Tech Solution s.r.l. is a Start-up focused on the digital integration of ICT, AI and UV. **University of Naples Parthenope** is a public Italian university with a background in the science of navigation, maritime economy, computer science, computer vision. **BI-REX** is one of the 8 Italian Competence Centres with a specific focus on Big Data, innovation processes, and the adoption of enabling technologies. **CINECA** is the largest Italian HPC centre and cooperates with academia and industrial partners.



Industry Sector:
Environment
Technology used:
HPC, AI

Find out more



The Challenge

Marine litter is a problem for the planet. Green Tech Solution sets out to automate the collection of marine litter by integrating Neural Networks and Deep Learning logic into its existing approach. The existing solution consisted of the use of an Unmanned Aerial Vehicle (UAV) to monitor the litter. The inaccuracy of the predicted litter speed and direction forced the UAV to remain close to the litter before its collection by a catamaran to monitor any possible changes in its position. The existing recovery strategy only focussed on one piece of litter at a time and led to long recovery paths and times for the catamaran.

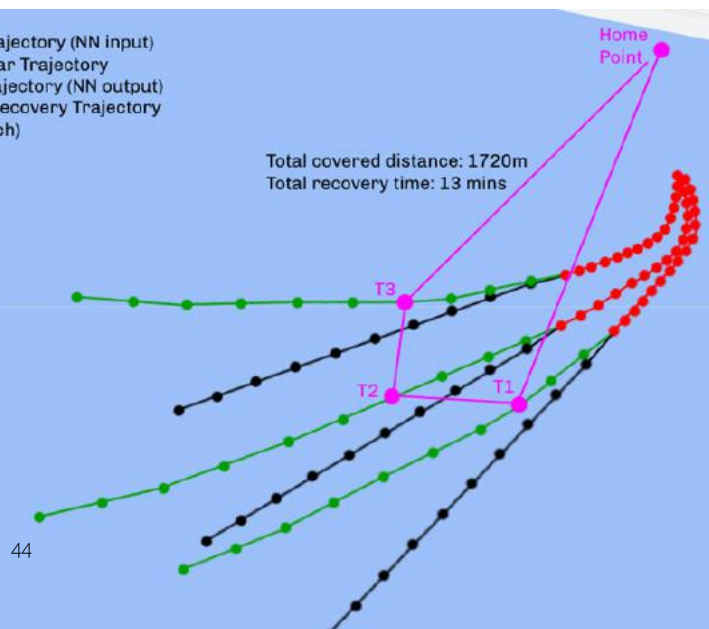

The Solution

The new HPC-based approach "Litter Hunter" predicts the litter's various trajectories and thus calculates an optimised recovery trajectory through the use of two neural networks and a newly developed multi-objective optimization algorithm. The first neural network acquires the aerial images of waste objects as input, identifies the position, and classifies them in terms of size, materials, and buoyancy level, while a second neural network predicts the trajectories of the observed litter by combining this information with meteorological and oceanographic data. An algorithm uses the predicted trajectories to compute the 'best' trajectory to be followed by the catamaran to collect the most litter while minimising time and distance.

The Impact

The service now allows an area of 1 km² to be covered in a single operation and about 100-200 pieces of waste to be collected. As the neural networks improve over the years due to Reinforcement Learning, the system is estimated to allow up to 1,000 floating objects (>25 mm) to be automatically collected per km² of the area in a single day of operation (expected by 2025).

The following are the main identified guidelines of the business strategy:

- 4 sales packages (duration min. 1 month / max. 6 months) designed to optimize the cost per contact with the customer.
- Focussing on the investment in drones and boat systems in the 3rd year (reaching 25 available systems) will increase commercial activity.
- Optimization of the services, prices, and fleet management cost will generate a different value proposition in comparison to potential competitors.

Maritime municipalities will reduce cleaning costs by up to 80%. In the medium term, municipalities will benefit from a platform to predict floating waste on a local scale and improve their environmental planning. The new service will enable the recovery of tonnes of plastic or other materials from the sea for recycling.

Benefits

- An estimated 60% reduction in energy consumption of vehicle batteries used per km² of operation.
- A reduction of 80% in time-to-planning, 50% in time-to-recovery and 40% in maintenance costs.
- A price for services of €2k-3k per km of road.
- Market expansion outside Italy, reaching 2,000 km of EU coastline served (Greece, Spain and Norway) in the next 5-6 years.



AI-Aided Wind Flow and Gas Dispersion Simulations in Cities

Organizations

Bettair Cities S.L. is a Spanish SME focused on deploying hyper-local real-time air quality monitoring networks in cities that identify the sources of pollution street by street to provide actionable information to the different stakeholders. **Barcelona Supercomputing Center** was established in 2005 and serves as the national supercomputing facility. Its mission is to research, develop and manage information technologies to facilitate scientific progress.



End User



HPC Centre & Provider



Barcelona Supercomputing Center is part of the Spanish NCC.



The Challenge

Urban air quality is influenced by complex atmospheric dynamics, urban geometry, land use, and traffic patterns, leading to very different pollutant distributions at microscales. As a consequence, any high-accuracy air quality map needs to use either a very dense network of sensors that measures pollution in real-time and/or high computational resources to process the data and model the distribution of pollutants with high spatial and temporal resolution.

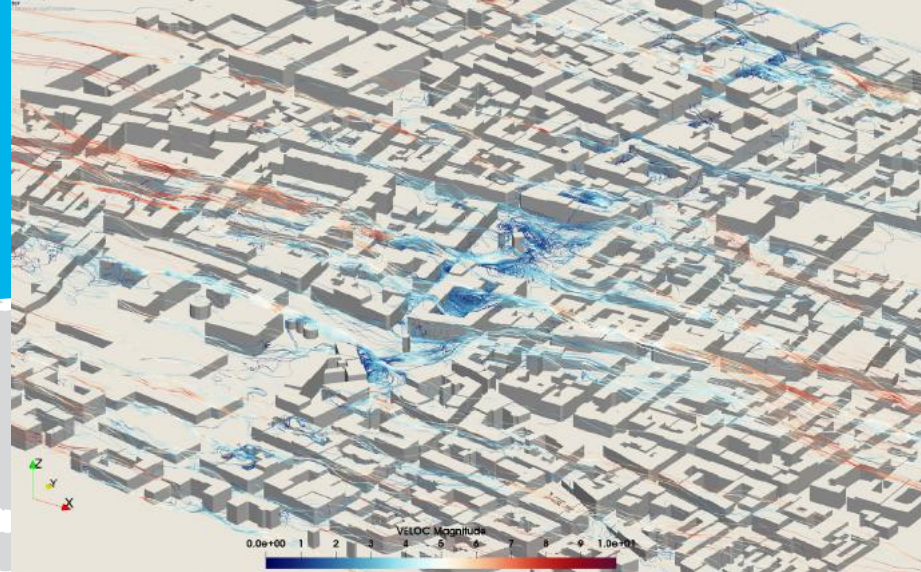
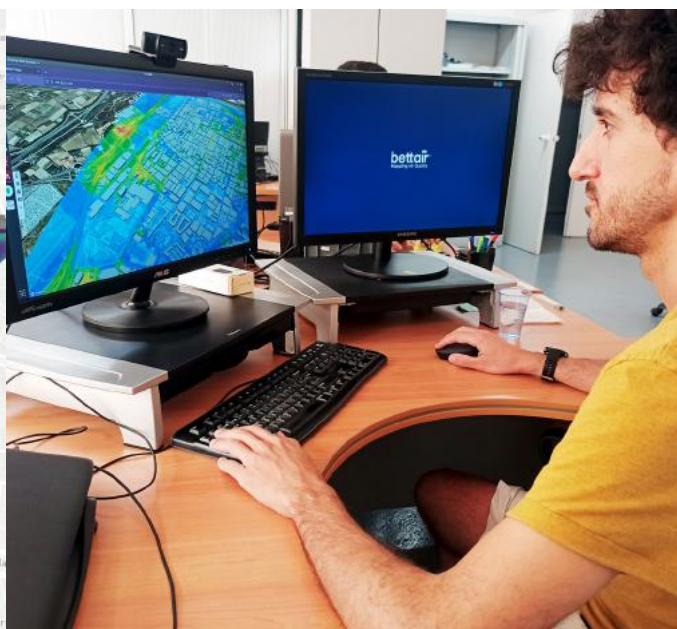

Industry Sector:
Environment
Technology used:
CFD Simulation

Find out more



The Solution

Using 30 3D models of 1km² areas of real urban geometries from European capitals as a basis, a dataset of approximately 30,000 256 m x 256 m areas was built. These urban geometries were used to perform CFD simulations of the wind flow for three different wind directions and the pollutant dispersion generated by traffic with a high spatial resolution. Deep Neural Networks were trained to learn the results of these simulations at different heights. Using AI models, simulations of new urban geometries can now be performed instantaneously with high precision. These models have been added to Bettair's platform to provide information about air quality and local emissions in real time.

The Impact

Bettair's ultimate aim is to help improve the air quality in local communities by providing accurate and actionable information. Organisations want to raise awareness and work together with stakeholders to create policies and push initiatives that improve air quality. As a result of this experiment, Bettair has created an energy and computationally efficient low-cost AI solution to model air quality in cities with up to 1 m² resolution, in near real-time. This type of precision and resolution is currently out of reach for any competitor due to the computational requirements of the CFD simulations with scientific software. The cost of the service provided by Bettair is up to 95% lower than the competitors with similar spatial resolution and runs in real-time. The expected revenue for this year will be two or three times higher because of the new service. Bettair is able to combine sensor measurements with AI simulations and extract precise information about the local emissions and pollutant concentrations in the cities. This information is then made available on Bettair's platform and enables individuals and communities to take collective actions to improve air quality for everyone. These solutions are already being tested in big cities (e.g. Rome) and smaller cities (e.g. El Prat de Llobregat).

Benefits

- The simulation cost per km² is reduced from €1,850 to less than €1,00.
- The spatial resolution of the real-time modeling capabilities is enhanced from 100 m² to 1 m².
- The experimental setup time for new cities is reduced by 80%.
- Access to new markets: municipalities and regional governments that could not afford classical modeling before.



Reservoir Monitoring by AI-Enabled Exploitation of Satellite Imagery

Organizations

ARESYS is an Italian SME designing and developing ad-hoc monitoring solutions, using microwave Radar/SAR imaging, seismic surveys, and vibroacoustic sensors. **GGD-DICEA-SAPIENZA** is the largest university in Europe. The Geodesy and Geomatics Division (GGD) is part of the Sapienza University of Rome. **SORICAL** is a public institution that oversees the management of water resources and reservoirs for the Calabria region. **CINECA** is the largest Italian HPC centre and cooperates with academia and industrial partners.



End User



Domain Expert



Technology Expert



HPC Provider



CINECA is part of the Italian NCC.



The Challenge

Aresys performs high-performance data analytics of optical satellite imagery using Sentinel-2 images for the continuous monitoring of water reservoirs, which due to water shortages, periods of drought, and extreme weather events is a critical issue for all European countries. However, the amount of data and the required processing sequence calls for on-demand HPC resources in order to deliver necessary added value to customers.



Industry Sector:
Environment
Technology used:
HPC, AI

Find out more



The Solution

Aresys designed a new service where Sentinel-2 optical images are used to identify reservoir water surface variation over time, without the need for in-situ measurements. The water surface is estimated based on proper geometric and radiometric processing using the latest Deep Learning results to cope with the Sentinel-2 data resolution. HPC resources are necessary for the AI-assisted processing steps and to provide the starting 3D reservoir model based on historical data sets.

The Impact

Smart monitoring and the space economy are both growing sectors in Europe. Moreover, as significant risks are caused by water scarcity conditions and drought events, especially in southern Europe, better management of freshwater has a significant social and environmental impact. The new Aresys SaaS service targets customers involved in the freshwater management cycle allowing them to improve the management of their reservoirs, thus reducing the threat of water scarcity in Europe. The ability to exploit on-demand computing power from HPC providers makes the business suitable for a consulting SME such as Aresys, allowing it to sustain a highly variable number of customers while providing historical data analysis promptly. Aresys plans to sell the demonstrated service to 20% of Italian reservoirs of which there are about 110 according to the Italian Dam Registry, with a revenue of €550,000 for the first year. The value of the addressable European overall market, i.e. the current expenditures for reservoir monitoring, could be estimated at more than €200 million.

Benefits

- Aresys now offers a new, profitable SaaS service for reservoir monitoring.
- The service – using on-demand HPC resources – can handle many customers efficiently.
- Sorical lowers monitoring costs for reservoirs by €15,000 per reservoir.
- Aresys set up a dedicated group (3 new jobs) for satellite optical data processing and exploitation.



High Fidelity Modeling for Small Wind Turbines

Organizations

EUNICE WIND SA is an SME member of the EUNICE ENERGY GROUP. Since 2001 the group has been active from the construction of power generation units up to the development and operation of renewable energy source (RES) investments. EUNICE manufactures a 50-kW small wind turbine called EW16 Thetis.

FEAC Engineering P.C. is a Greek engineering & consulting SME, highly specialized in simulation-driven product development & physics-based Digital Twins.



End User



Technology Expert



The Challenge

To enhance the efficiency and cost-effectiveness of its wind turbines, EUNICE is aiming to replace physical testing with CFD simulations. The accurate prediction of temporal and spatial scales within a multiscale CFD model requires advanced meshing techniques and high-resolution numerical models. Building a precise simulation model necessitates significant computational resources and know-how which exceed the computing capacity of EUNICE.



Industry Sector:
Environment
Technology used:
HPC, CFD
Simulation

Find out more



The Solution

The partners developed sophisticated CFD simulation models using highly dense computational meshes consisting of over 50 million cells, a reduced time step approach, and the Detached Eddy Simulation method to test and optimize wind turbine performance at the actual operation site, including information about terrain and elevation available from satellite images in the CFD model. In total, about 485,000 CPU hours were used for the simulations, which were validated with an experimental data set.

The Impact

For EUNICE, the material and logistics costs of constructing a new wind turbine solely for testing purposes are approximately €300,000. Replacing those tests with HPC-based CFD simulations reduces costs to only 10-17% of the total expense, depending on the complexity of the HPC calculations.

Since the stresses on the blades are known through the simulation results, predictive maintenance can be done which reduces costs. Together with an increase in energy yield, achieved with the optimal blade pitch strategy found in the experiment, faster design cycles give EUNICE a competitive advantage.

FEAC Engineering gained more expertise in the wind energy sector and valuable experience in high-fidelity simulations by utilizing large-scale HPC resources.

Furthermore, the developed solution leads to the improvement of emerging designs and more advanced wind turbine models that contribute to environmental sustainability and avoid unnecessary waste from non-recyclable composite materials utilized in the test turbines' construction.

Benefits

- Testing costs were reduced by up to 83% compared to a typical physical test installation.
- Increased competitiveness through faster design cycles.
- Lower operational expenditure which leads to higher levelized cost of electricity.
- Assist the European Commission directives towards a green and sustainable future.

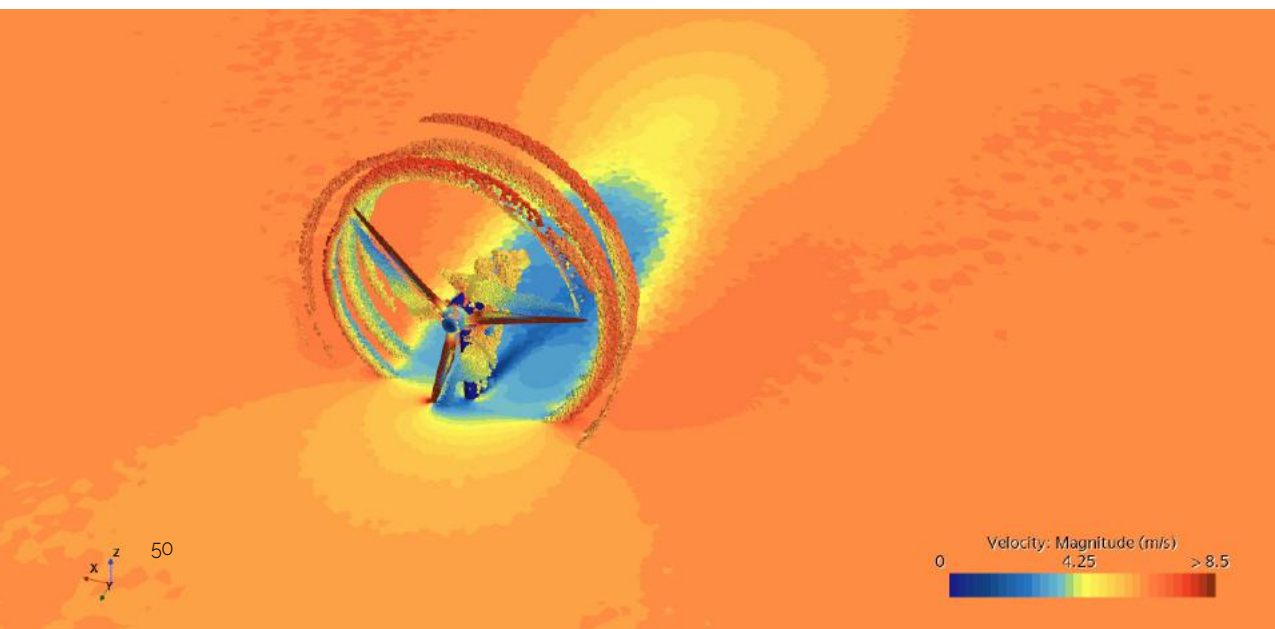



Solving Ambitious Challenges in Wastewater Treatment Using HPC in CFD Simulation

Organizations

AeroFEM GmbH is a Swiss SME in the aerospace sector. It offers engineering and consultancy services for a wide range of industries. **TK Consult AG** provides integrated water management, hydraulic engineering and geothermal energy services. **HOLINGER Ingenieure GmbH** operates in urban water management, energy and environment. **Elkuch Group** is one of the leading suppliers of waste collection and wastewater treatment systems. **HLRS, University of Stuttgart** is one of the three national supercomputing centres in Germany.



End Users



Technology Experts



HPC Provider



HLRS is part of the German NCC.



The Challenge

Europe's freshwaters are increasingly polluted through waste: improper drug disposal generates pharmaceutical pollution; solid waste decomposes and creates micro-pollutants. The 2021 EU regulation will drive operators to upgrade their facilities for higher wastewater quality, with annual investments estimated to approach €4 billion. This provides a business opportunity for the experiment's companies by exploiting digitalization for technology offerings and improved water management.

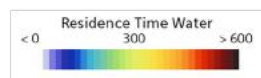
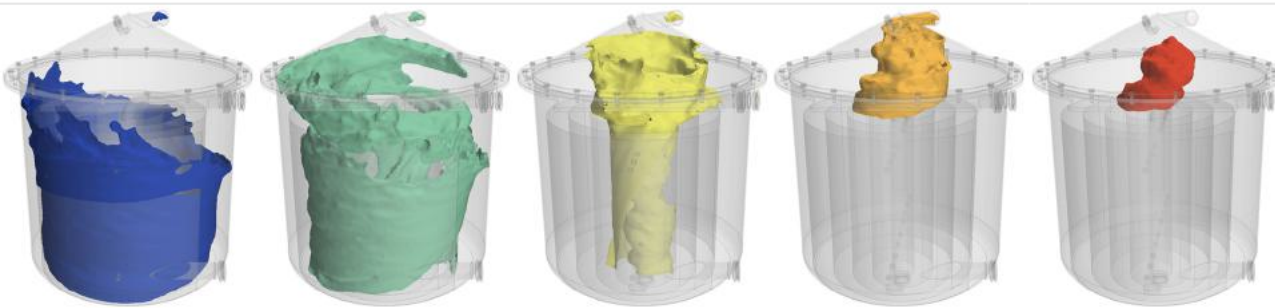

Industry Sector:
Environment
Technology used:
**HPC, CFD
Simulation**

Find out more



The Solution

Two purification technologies were considered: ozonation covers pharmaceutical pollution, while pressure flotation deals with solid suspensions and micro-pollutants. Each solution will be managed through a digital twin considering the system's CAD geometry and the CFD model of the purification technique. The relevant parameters are identified to optimise the digital twins. An HPC-based workflow is provided to empower SME user processes through efficient systems-/ process scaling and optimisation.

The Impact

The innovative IT solution provides all participating companies with a competitive advantage in wastewater management and other related sectors, which represents a massively growing market. This should provide a major incentive for other SMEs and start-ups to take up the technology and enter that market. HPC Centres benefit significantly from an additional demand for HPC resources to cut design and construction turnaround times with new SME customers using their resources to run efficient optimisation cycles. Eliminating pharmaceutical contamination from water reduces the risk of antibiotic resistance while removing micropollutants reduces the risk of health-damaging effects caused by potentially trapped and accumulated micro particles in different tissues and organs, such as lungs or placenta. Overall trapping and accumulation of residues of pharmaceuticals and micropollutants in our global environment as well as the whole human food chain will decrease.

Benefits

- Customised digital workflow brings speed-ups of design process of 50-70%.
- New services by AeroFEM and TK Consult generate expected growth of 20-40% in total sales.
- Elkuch Group and Holinger expect growth of 30-50% in sales of systems and services.
- Savings for federal and municipal authorities in public construction projects of up to 30-40%.
- Strategic alliances between federal/ municipal authorities and their contractors.



A Pediatric Simulated Dosimetry Platform for Clinical Use

Organizations

IKH is an SME and a regional leader in large-scale ICT solutions in the fields of: Digital Government, Digital Health, and Industrial Innovation & Robotics. **BIOEMTECH** is an SME in the field of biomedical engineering offering hardware solutions for medical imaging and dosimetry applications. **GRNET** provides networking and cloud computing services to a broad range of public and private sectors.



End User



Domain Expert & End User



HPC Expert



GRNET is part of the Greek NCC.



The Challenge

Radiation dose calculations from radiopharmaceuticals in nuclear imaging have been a challenge to the scientific community and clinicians, as no commercial solutions for personalised dosimetry existed previously. In clinical practice, there are only rough estimations of the administered dose that a child should receive. Obtaining improved dosimetry protocols for children is difficult through standard clinical practices such as experimental dosimetry and validation. Current solutions and the traditional approaches lack personalisation of dose assessment on a patient basis.

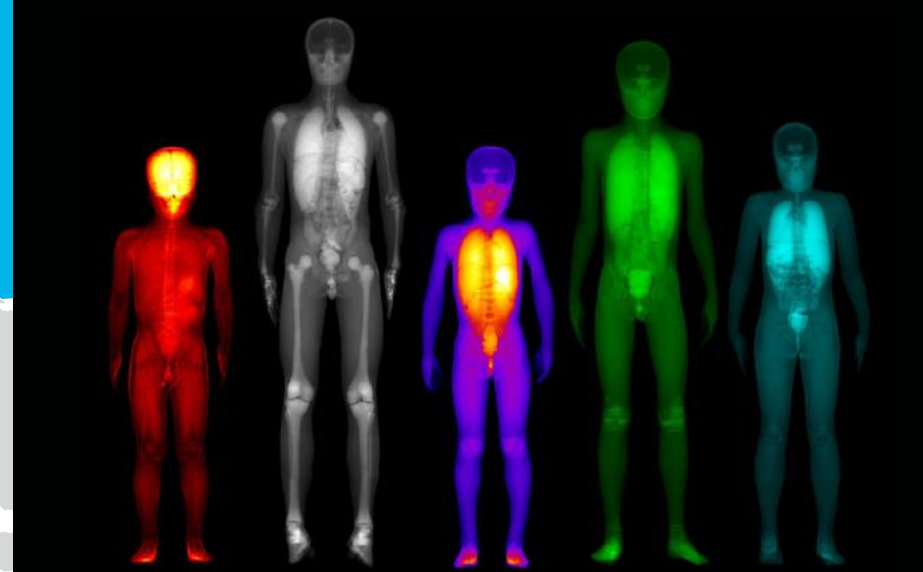
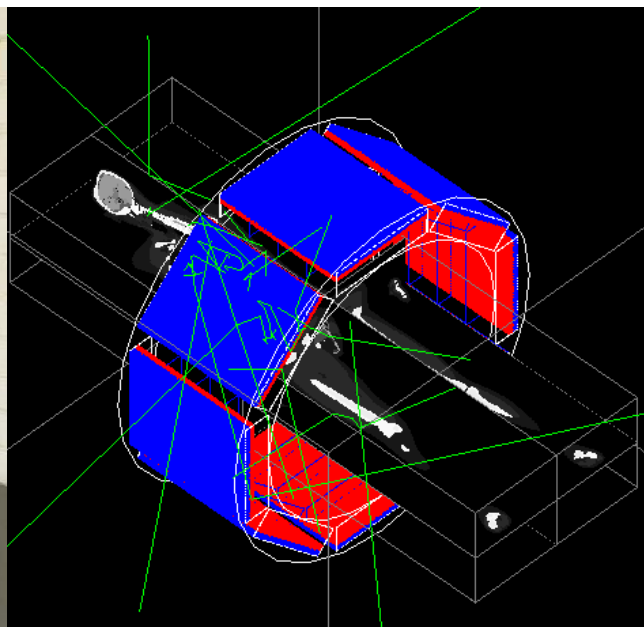
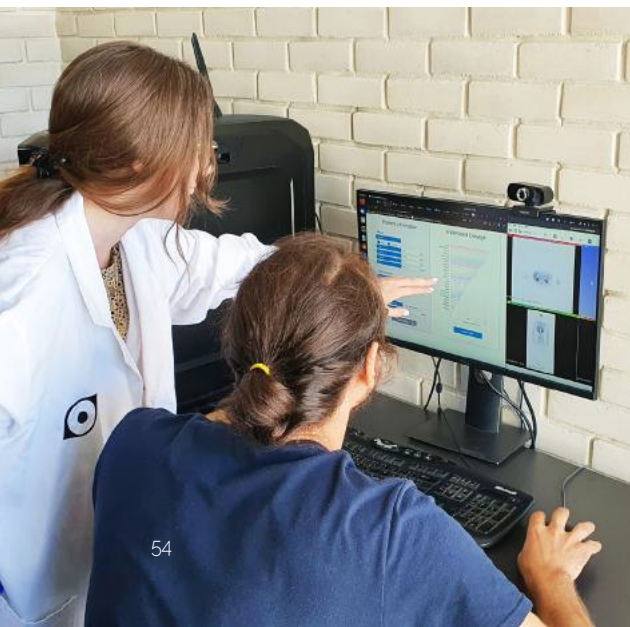

Industry Sector:
Healthcare
Technology used:
HPC, AI, Monte Carlo Simulations

Find out more



The Solution

The involved organisations exploited all the appropriate tools for creating a precise dosimetry software, which allow clinicians to assess internal dosimetry and optimise Nuclear Medical imaging clinical protocols toward personalised medicine. By employing HPC resources, a speedup by a factor of 80 was achieved, permitting a high level of accuracy in predicting the absorbed doses of radiation in organs. A predictive dosimetry model based on ML algorithms was developed and trained with computed results, permitting an individual dose calculation for each new patient, taking into account personalised anatomical characteristics.

The Impact

PediDose is expected to strengthen IKH and BIOEMTECH in the EU industry of medical software and provide these SMEs with great advantages. PediDose has been technically integrated into the evorad® suite, a competitive software for medical imaging. After further maturation and obtaining the CE Mark and FDA approval, this add-on is expected to generate additional net income for IKH of about €1,25 m within the next five years. PediDose will be offered on a license basis to other vendors of medical software. Further business opportunities are anticipated in an extension of the approach for adult patients or specific groups like obese patients or pregnant women. PediDose will permit BIOEMTECH to enter the medical software market through a business partnership with IKH and utilise the existing customers of BIOEMTECH's imaging devices for extending its portfolio. Personalised dosimetry supported by PediDose can lower administered doses and minimize radiation's harmful effects for a very large number of treated children. The proposed solution provides a great potential for expansion to other patient groups.

Benefits

- Significant strengthening of the value proposition for IKH's product Evorad® achieved.
- €1.25 m additional total income expected through increased sales of Evorad®.
- Medical market entry for BIOEMTECH facilitated through a partnership with IKH.



Advanced HPC Based Drug Discovery with Converged Deep Physics and AI

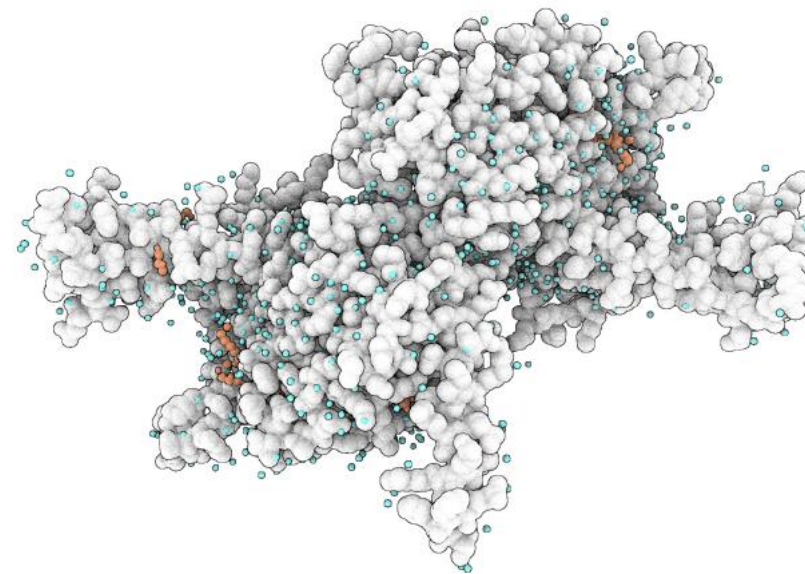

Industry Sector:
Healthcare
Technology used:
HPC, ML, AI,
Molecular Dynamics
Simulations

Organizations

Iktos is a French start-up SME specialising in AI applied to drug discovery. Iktos has developed a retro-synthesis algorithm and generative AI for drug design. **Qubit Pharmaceuticals** is a French start-up SME specialised in physics-based simulations for drug discovery. Using advanced simulation software and AI-enhanced medicinal chemistry, the company develops novel drug candidates and identifies their modes of action against challenging targets.



End User



Domain Expert



The Challenge

The discovery phase of new drugs can be costly, time-consuming and is often covered by specialised companies. Computer-aided drug design has emerged as a new *in silico* method for the discovery stage and many SMEs are competing in this field. The tendency is to outsource the research effort outside of pharma companies to contract research organisations. The SMEs Iktos and Qubit Pharmaceuticals, are part of this ecosystem and help many pharma companies advance their research projects.

The Solution

The involved organisations conceived a drug discovery strategy and toolchain focused on small molecules targeting novel proteins. AI algorithms generated novel molecules, and high-end calculations predicted how the compounds bind to challenging targets. The combined technology can speed up the drug design process and improved the quality of the generated compounds, thereby improving the entire drug discovery process. The combined workflow was applied to a target USP7, involved in cancer pathways. Progress in the drug discovery stage for this target could lead to drugs for various kinds of cancer.

Find out more



The Impact

The newly developed *in silico* framework for drug discovery has the potential to cut drug discovery time and reduce overall drug development costs, which leads to savings of several million Euros. As time constraints and agility become crucial in the pharmaceutical industry, a new service offered through Iktos and based on this framework will be a competitive advantage in a challenging market and represent an unrivalled product especially for hard-to-drug targets.

Additionally, the novel hit families of drugs targeting USP7 already discovered during the experiment will support the two SMEs' internal drug discovery pipeline. An estimated €2 Million will further be invested to bring these hit families to the pre-candidate stage. Having successfully reached that stage, the SMEs will be able to enter into a licensing agreement with pharma companies. Qubit Pharmaceuticals intends to use the new toolchain in further *in-house* drug discovery programs promising high profit by exploiting considerably increased success rates (40% vs 10%) enabled by the newly developed technology.

Benefits

- A unique physics-based AI-assisted workflow cuts the drug discovery time by 25% and reduces the cost of drug development by 20%.
- Novel, highly profitable services to be offered by the SMEs.
- Discovered promising compounds which could lead to new cancer drugs, potentially generating substantial income for the SMEs far beyond the invested sums.

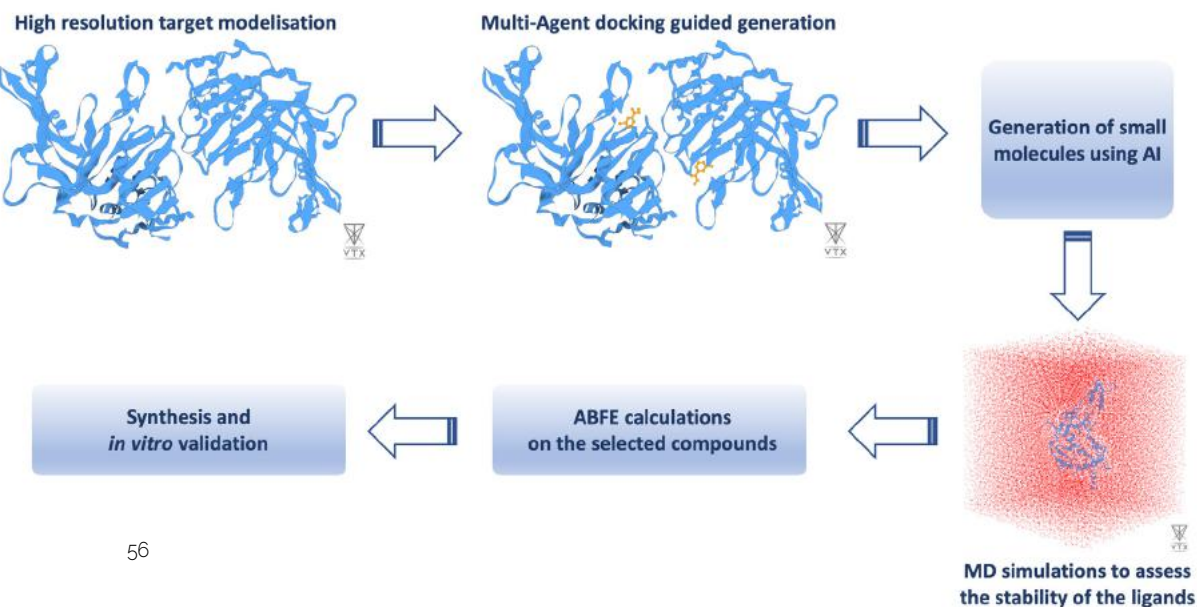



Cloud-Based HPC Platform to Support Systemic-Pulmonary Shunting Procedures

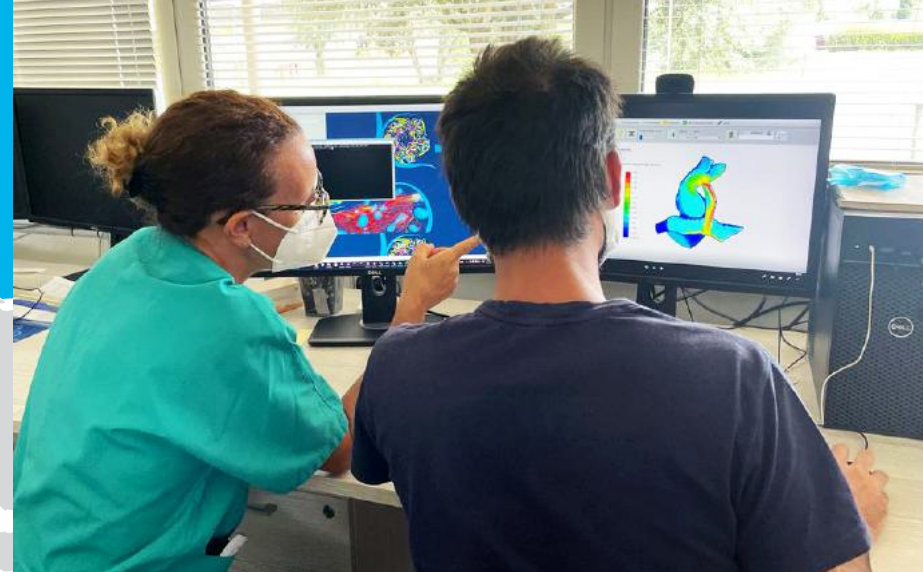

Industry Sector:
Healthcare
Technology used:
HPC, CFD
Simulation

Organizations

InSilicoTrials Technologies SpA is an SME that promotes innovation and commercializes in silico tools for healthcare through a cloud-based platform. **RBF Morph** is an ISV that develops the RBF Morph software and an expert in CFD and FEA. **Fondazione Toscana Gabriele Monasterio** is a healthcare public entity and a leader in the field of cardiology. **RINA Consulting** provides a wide range of services covering the whole project life cycle, site engineering and maintenance management. **CINECA** is the largest Italian HPC centre and cooperates with academia and industrial partners.



End User	ISV	Application Expert	Technology Expert	HPC Centre & Provider
InSilicoTrials	rbf™	Fondazione Monasterio la ricerca che cura	RINA	CINECA
			CINECA is part of the Italian NCC. EUROCC ITALY	

The Challenge

The experiment consortium decided to work in the challenging field of Congenital Heart Disease. Without the ability to alter the prevalence of CHD, interventions and resources must be focused on improving survival and quality of life. In this context, the Modified Blalock Taussig Shunt (mBTS) is the most common palliative operation performed but is associated with significant morbidity and mortality. A simulation of effects could support the medical decision, yet this requires substantial know-how and computing power, in order to provide high-quality results and the subsequent surgery in a short timeframe.

The Solution

The partners generated an affordable decision support web application Copernicus that, thanks to a medical digital twin (MDT), allows surgeons to optimally approach the mBTS medical intervention. Copernicus circumvents problems by generating the MDT through a Reduced Order Model of a patient-specific vascular district, condensing complex computations can be used interactively to vary its dimension and positioning. With a dedicated user interface, the medical staff is thus able to inspect the MDT of the patient and observe how the shunting layout influences the fluid dynamics of the involved impacted area, helping to finalise the decisions on surgical intervention.

Find out more



The Impact

The impact of the solution proposed by Copernicus at the clinical level is highly relevant: The combination of speed and interactivity permits surgeons to find the best treatment option for CDT, thus lowering the incidence of post-surgery complications and reoccurrence, leading to a decrease in the days of hospitalisation of treated patients and related costs. For Fondazione Toscana Gabriele Monasterio, this could mean savings in the order of over €100k per year. InSilicoTrials Technologies will add the tool to its portfolio, pursue certification for clinical use, and commercialise it on the market through a SaaS approach, with shares held by RBF Morph and RINA-C, and using CINECA's HPC system as a backend. In addition, both RBF Morph and RINA-C will use the results to increase their presence in the healthcare market: RBF Morph by offering new functionalities in their software library, and RINA-C by offering consulting services backed by hardware and software leasing to medical device manufacturers and medical research clinics.

Benefits

- IST: Generating an increase in annual revenue of about €450k after 4 years.
- Clinicians: Surgery outcome improved, reducing hospitalization per patient by 5-6 days. FTGM: savings of more than €100k per year are expected.
- RBF: Expected increased annual revenue 4 years after the experiment is €250k, additional 2 qualified jobs/year.
- RINA-C: Expected increased annual revenue 4 years after the experiment is €200k.

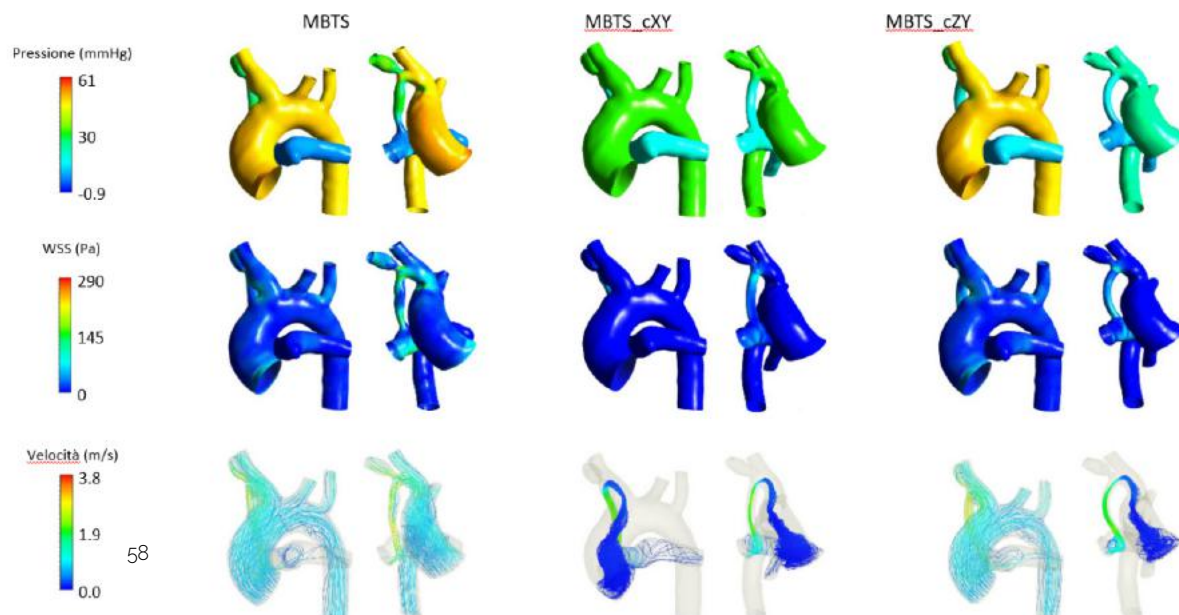



High-Performance Computing Enhances Treatment Precision in Breast Cancer

Organizations

CHOSA is a UK SME developing techniques to predict outcomes of treatments with anticancer drugs in patients using molecular models based on data from cell cultures exposed to drugs and selling this as a service to health providers. **AH-HMU** from the Hellenic Mediterranean University has a deep experience in molecular pharmacology and cancer biomarker identification. **JADBio** is an SME developing the JADBio automated ML platform for biomedical tasks, providing life-science professionals with effective analysis of molecular and clinical data with an accessible user interface.



End User



Domain Expert



Technology Expert



The Challenge

Breast cancer is a major health issue and many cancer patients fail to respond to the treatment. Lack of efficacy is mainly attributed to tumour variations at the genetic and molecular level, which clinical practice struggles to address. The emergence of new genomic technology combined with digitalization has delivered treatment regimens that assess the DNA, RNA, protein, and metabolites in the individual patient's tumour and integrate those into therapeutic decision-making. Current technologies focusing on just one or a few genetic biomarkers or using complex ex vivo laboratory tumour models are predictive of treatment outcomes only in highly selected cases.



Industry Sector:
Healthcare
Technology used:
HPC, ML

Find out more



The Solution

Using JADBio's tools and employing HPC resources, a huge amount of data on drug-like chemical compounds was processed to create ML models predicting the efficacy of drug candidates in cancer treatments. As a means of early validation of the ML models, biological text mining was carried out independently. It revealed eight specific models which are particularly interesting for breast cancer. After clinical validation, the models will be used to set up a complete platform to predict the efficacy of different cancer drugs for each individual patient, based on their biopsy readings. Clinicians will receive a report listing a number of relevant drugs that highlight those most likely to work for a given patient's cancer.

The Impact

At the moment, no similar solutions exist and therefore the resulting product AIDA has the opportunity to become a first-in-market product that can truly revolutionize the way cancer patients are treated. With a breast cancer incidence of over 780,000 in 2018 in the EU and USA alone, there is a huge market potential to be exploited with such a commercial response prediction test – even using very conservative assumptions. The market launch is expected in mid-2024 in Germany and Nordic countries, where 23,000 cases of breast cancer are newly diagnosed per year, offering a business potential of up to €69m, based on an anticipated price of €3k per service. Beyond those initial targets, the business model is highly scalable and the system can be applied to any tumour type and any drug that has demonstrated toxicity. Besides direct economic and clinical benefits, all partners will enjoy increased visibility in the biomedical market and scientific community, generate new intellectual property, and foster company growth. The HPC-based solution can play a role as a use case for promoting other diagnostic/prognostic/predictive applications in the field of personalized medicine, fostering wider application.

Benefits

- CHOSA targeting a USP in a market worth €69 million in Germany and Nordic countries leads to an expected additional revenue of several million Euro from mid-2024.
- More cancer patients with limited disease get the right treatment which could be lifesaving.
- More cancer patients with advanced disease live longer by avoiding ineffective treatments.

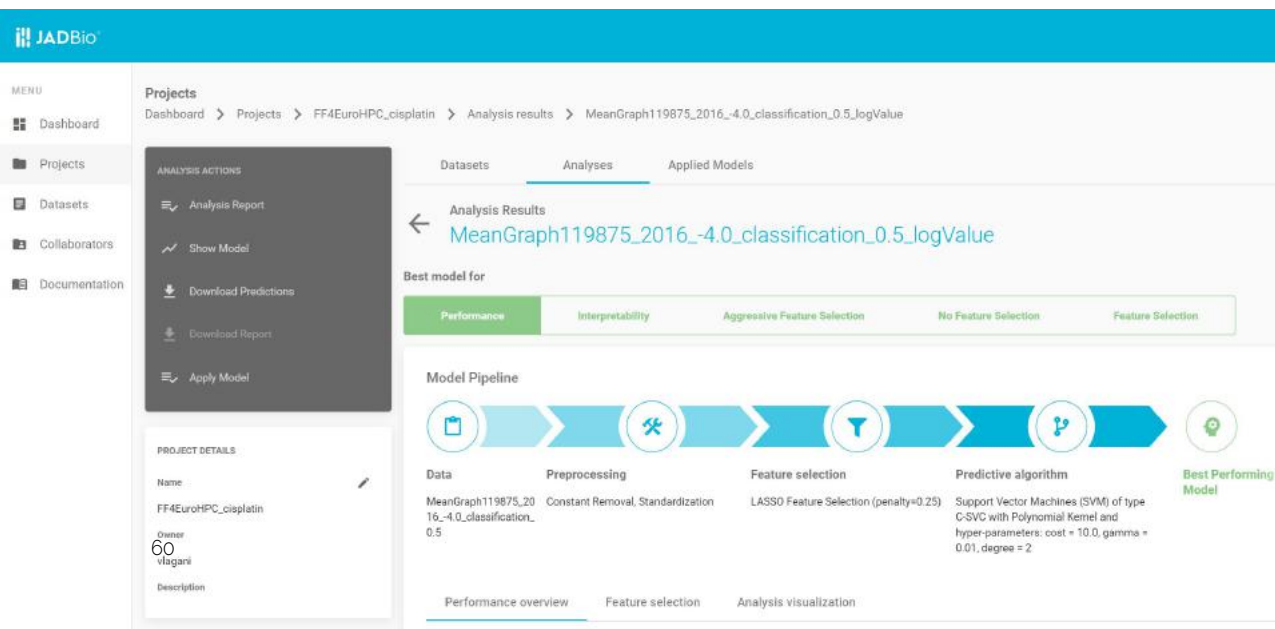



HPC Simulation for an Endourethral Sphincter Against Urinary Incontinence

Organizations

RELIEF is an SME whose main objective is to develop and manufacture devices for handling urinary incontinence. M3E is an SME with extensive experience in large numerical simulation. The Centre for Mechanics of Biological Materials is a research center established at the University of Padova with broad multi-disciplinary competence in in silico medical activities. CINECA is the largest Italian HPC centre and cooperates with academia and industrial partners.



End User



Application Expert



HPC Expert



HPC Provider



CINECA is part of the Italian NCC.



The Challenge

RELIEF has developed an innovative Artificial Urinary Sphincter (AUS), for the treatment of incontinence. In-vivo / in-vitro tests and a first-human pilot study demonstrated the feasibility, acceptability, and easy use of the AUS, but also the need for optimization of the final product design. Furthermore, a decision-support system (DSS) is needed to allow medical doctors to choose the optimal size of the device for each individual patient.

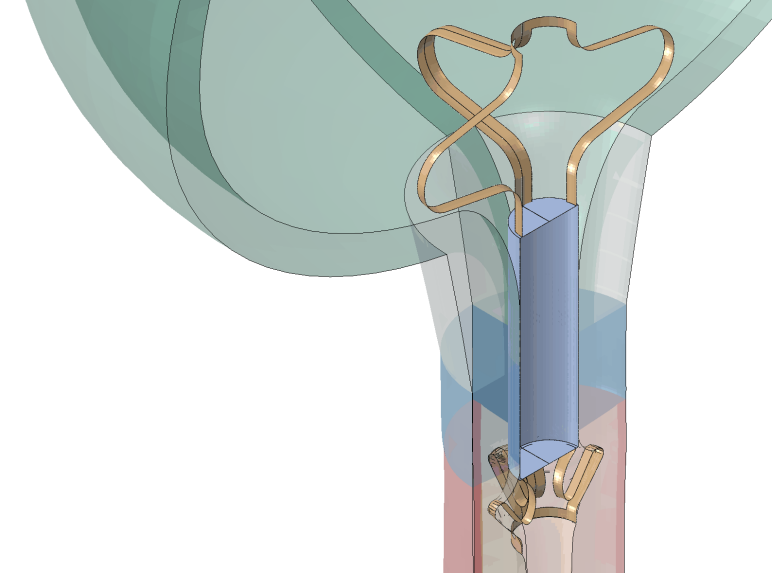
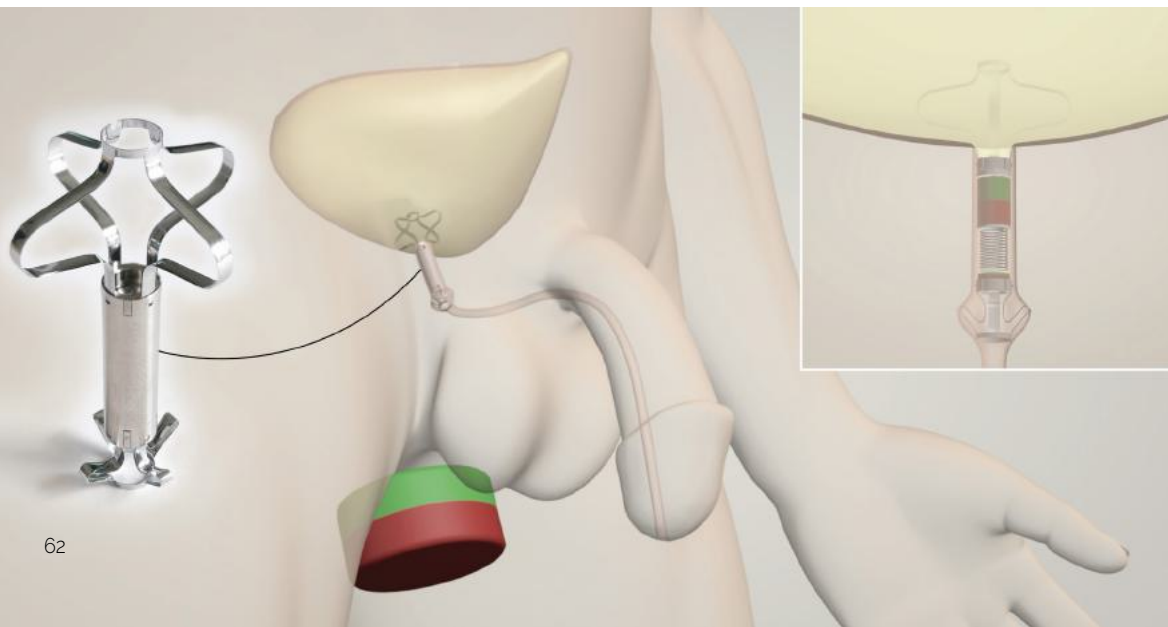

Industry Sector:
Healthcare
Technology used:
HPC, FEM
Simulation

Find out more



The Solution

Finite element analyses can be used to optimise the AUS shape design and also to define the key information required to select the device for individual patients. Thus, side-effects of implantation can be limited, medical doctors can easily choose the right size for a patient, and the patient's long-term satisfaction can be considerably improved. HPC-based simulations mean that the highly complex models needed to deliver results with sufficient accuracy are available within RELIEF's business workflow.

The Impact

- "In silico" investigation using numerical simulation gives RELIEF a disruptive boost in the development of the product via:
- Savings in design costs. A reduction of costs by €400 per device is expected. This sums up to more than €40,000 yearly.
 - Savings in experiment costs. Numerical simulations, powered by HPC systems, can reduce in-vivo experiments costs by up to 43%.
 - Faster time-to-market. This solution reduces the number of prototypes to be designed, manufactured, and tested.
 - A competitive advantage. RELIEF has built a DSS that allows medical doctors to easily decide the right AUS size for each patient, providing a more advanced service offer for its product.

This solution will also have a social impact considering:

- Reduction of in vivo tests. Digital models reduce the need for animals or cadavers for validation and optimisation purposes.
- Improvement of long-term patient satisfaction. Personalised selection of the AUS size promotes correct use and reduces undesired effects.

Benefits

- Drastic reduction of animal or cadaver tests for experimental validation and optimisation.
- €40,000 yearly reduction of production cost.
- 43% reduction in experimental cost.
- 6 to 12 months reduction in time-to-market.



Application of HPC Tools for the Optimization of 3D-Printed Orthopaedic Devices

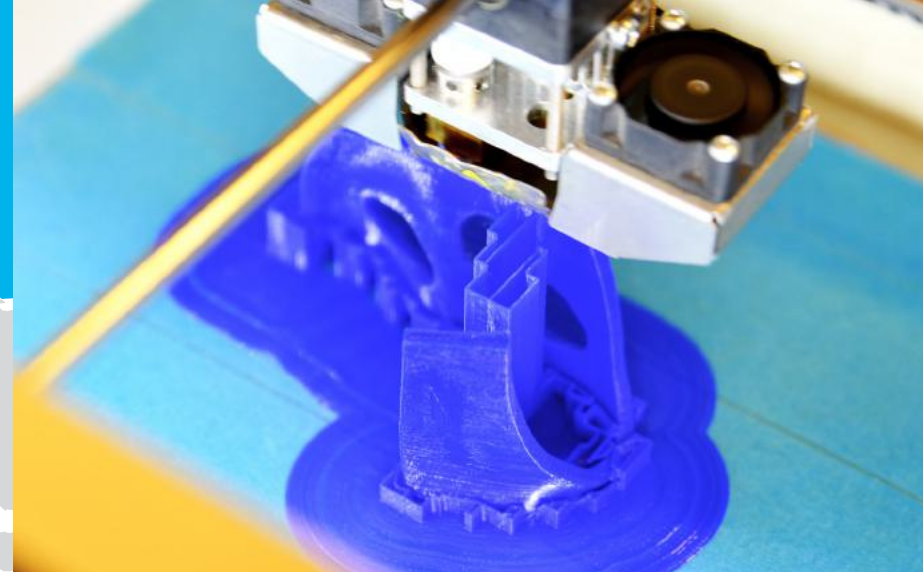

Industry Sector:
Healthcare
Technology used:
HPC

Organizations

CastPrint is a Latvian SME that provides clinics with custom-made 3D printed casts. **University of Latvia** provides both expertise in mathematical modelling and optimisation, as well as experience and technical capacity in material testing. **Riga Technical University HPC Center** provides HPC resources and expertise in HPC software setup and is the largest HPC provider in Latvia.



[Find out more](#)



End User



Domain Expert



HPC Centre

Riga Technical University and Institute of Numerical Modelling, University of Latvia are part of the Latvian NCC.



The Challenge

While 3D-printed casts deliver patients a high-quality product faster than traditional production approaches, their creation is nevertheless a time-consuming and resource-intensive process. Since the 3D scans used for production contain huge numbers of surface elements, processing the data on typical office computers is both slow and often unreliable, with software crashes resulting in data loss and delayed delivery to patients.

The Solution

The experiment partners have chosen to integrate parametric model optimization into the design process of the medical device. This involves using simulations to determine the most efficient shape for the cast, which in turn reduces the amount of material required and shortens printing times. The use of HPC enables faster and more effective simulations, automating certain aspects of the design process and ultimately reducing the time spent on it.

The Impact

Product time to end user decreased by 25%. This is achieved through shorter design and print times for the ordered 3D printed medical devices that reduces production costs by up to 15% and increases production capacity by 25%. Reducing the time between scanning and printing opens opportunities in new markets. Shorter printing times and less material used result in lower costs and thus CastPrints become more accessible for patients. Despite the fact that CastPrints are made out of Polylactic acid plastic that is made from sugarcane and is biodegradable, a 25% reduction in plastic use means less plastic waste. Similarly, a 25% decrease in printing times results in less electricity consumption used in printing the device itself. This contribution to the reduction of plastic waste and electricity usage is combined with improvements to the durability and wearability of the product.

Benefits

- 20% reduction in labor hours for cast design, which also reduces the risk of human error.
- Approximately 25% reduction in production material use through topological optimization.
- 25% reduction in production time through material optimization and shorter printing durations.
- Up to 15% reduction in production costs.
- Up to 25% enhanced production capacity at CastPrint.

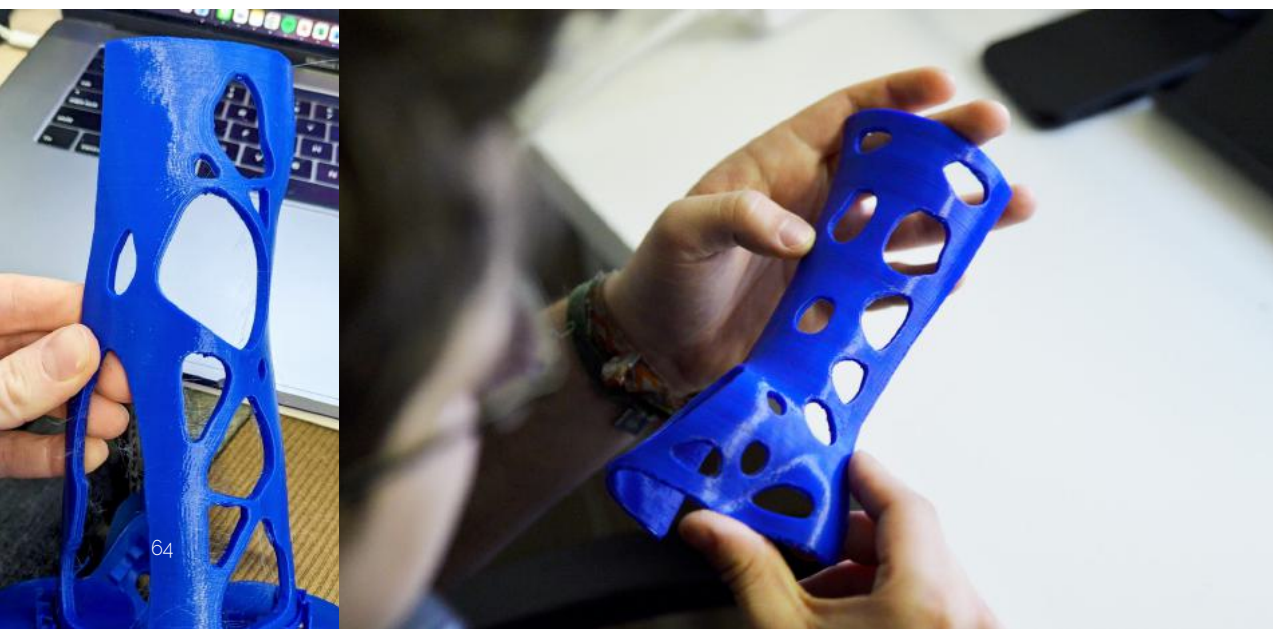



Real-Time Heart Monitoring of Thousands of Patients

Organizations

Innovation Doeel has developed and sells the ViewECG software certified as a medical device for remote real-time ECG monitoring. **Universität Klagenfurt** provides expertise in developing efficient, scalable HPC workflows. **Ss Cyril and Methodius University in Skopje** support the deployment of the developed HPDA solution.



Ss Cyril and Methodius University in Skopje is part of the North Macedonian NCC. 

The Challenge

ECG monitoring is used to detect arrhythmias and alert about potentially life-threatening heart conditions. Innovation Doeel's ViewECG software uses real-time ECG data from wearable sensors and is capable of monitoring dozens of patients without them needing to be in a hospital. Innovation Doeel's aim is to improve the existing machine learning (ML) arrhythmia detection and to scale ViewECG up to monitoring many more users at the same time.

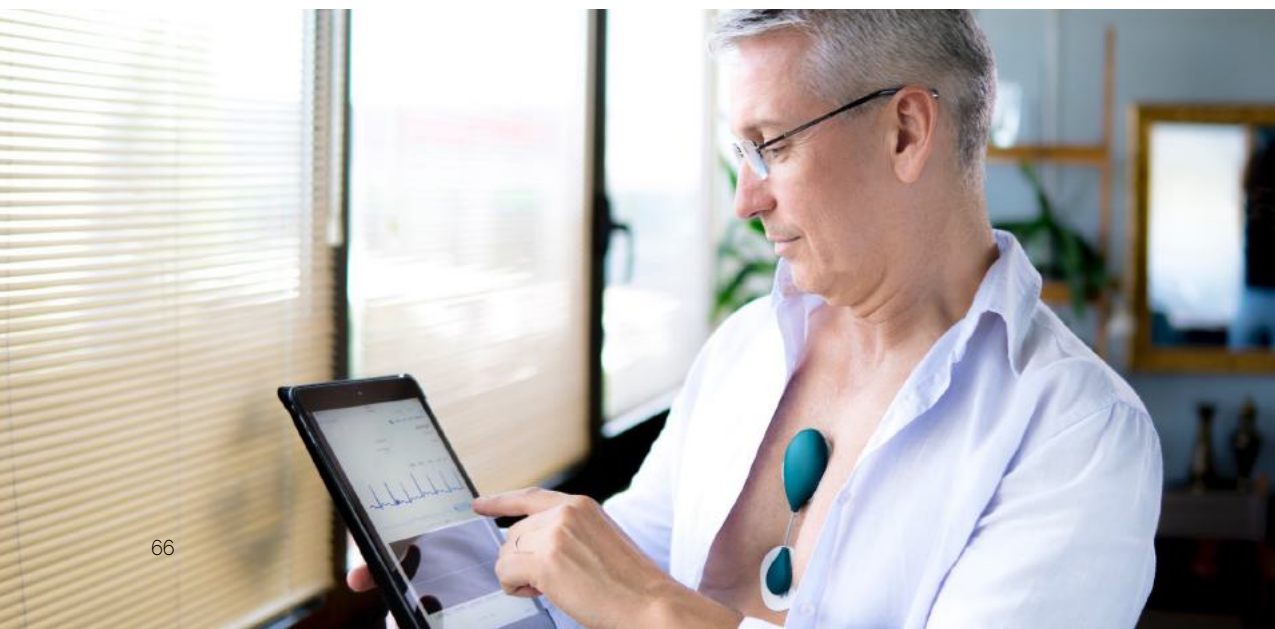

Industry Sector:
Healthcare
Technology used:
HPC, ML, HPDA

[Find out more](#)



The Solution

GPU-based HPC (using in total around 11,000 core hours and 5,200 GPU hours) was used to train a new ML model to detect specific heart arrhythmias, improving its accuracy and reducing the error rate by 50%. To efficiently process thousands of incoming ECG streams with high velocity and data volumes, a container-based service was developed whose workflow manager handles multiple HPC systems. This service system avoids redevelopment and replicated administrative tasks across heterogeneous servers.

The Impact

The experiment realized a solution that ensures operational resilience with a robust solution for easy business scale-up. The new service reduces the costs for system administration, software upgrades, and maintenance, resulting in a more efficient and profitable business. Thanks to the achieved scalability boost to tens of thousands of users, in particular, the ability to handle the associated ECG analysis requests concurrently, Innovation Doeel expects to double its revenue through additional sales. The improved arrhythmia detection, reducing errors by 50% and achieving an accuracy of 90%, will significantly increase the competitiveness of Innovation Doeel's service. Through this new service, medical doctors can simultaneously monitor the health status of multiple outpatients without requiring their physical presence in a hospital, thereby reducing costs to the health system significantly. In particular, the service will contribute to the early detection of dangerous arrhythmias to prevent severe heart damage, improving overall healthcare and increasing life expectancy.

Benefits

- Innovation Doeel expects to double its revenue due to the better scaling service.
- 50% error reduction & 90% accuracy: a more competitive product with better arrhythmia detection.
- 25% increase in efficiency and profit due to reduced costs and reduced software administration.



A Digital Twin for Airflow and Inhaled Drug Delivery in Human Airways

Organizations

One Simulations is a Dutch SME specialised in CFD simulations. **RBF Morph** is an Italian SME developing mesh morphing tools for topology-preserving shape variations. **Grep IT** is a Dutch SME providing technical support in the field of HPC. **Fondazione Toscana Gabriele Monasterio** is an Italian research hospital specialised in cardiovascular and pulmonary pathologies. **TU Delft** is the oldest and largest technical university in The Netherlands.



End User	ISV	Domain Expert	Medical Expert	HPC Provider

The Challenge

Respiratory diseases such as asthma and Chronic Obstructive Pulmonary Disease are caused by local narrowing of the human airways. The efficacy of inhaled drugs crucially depends on drug particle distribution, which is currently assessed by (potentially harmful) inhalation of radio-labelled drugs. Large-scale CFD particle simulations, such as offered by One Simulations, could be an alternative. Yet, this is time-consuming, error-prone and costly.

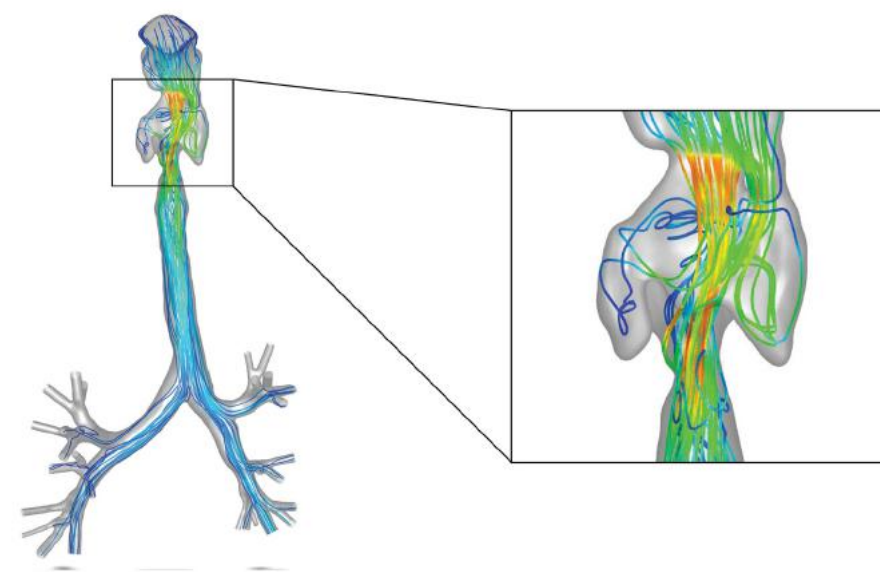

Industry Sector:
Healthcare
Technology used:
HPC, CFD
Simulation

Find out more



The Solution

The experiment developed a Digital Twin (DT) able to predict the particle deposition of inhaled drugs for individual human airways. It compresses 1000 high-resolution CFD runs on a g60-core HPC system into a Reduced Order Model giving accurate predictions of particle deposition. Clinical users can now simply feed a medical image into the system and tap the canned power of these simulations with a click to optimise the drug particle size without the need for lengthy and costly CFD runs.

The Impact

The created DT is a valuable asset for One Simulations since it can offer an alternative to hospitals for harmful radiative testing and/or expensive and time-consuming CFD simulations, even in emergency situations. Hospitals/clinics can use the solution directly with the consortium operating the DT or by using a licensing structure. Pharmaceutical companies can also benefit from the DT as it can be used to optimize their drug particles or inhalers. The solution will also be offered through consultants who are already selling technical solutions to the healthcare industry, thus easily targeting a large group of customers. This experiment allows One Simulations to expand into the healthcare industry and to gain valuable experience in creating predictive DT's as the principle can be applied in many other industries. By deploying this unique tool into the market One Simulations expects to have an increase in 5 high-level jobs and a yearly turnover increase of €1 million within 5 years.

Benefits

- Unique solution offers a practical clinical alternative to harmful radio-labelled drug testing.
- SME expects to create 5 high-level jobs within 5 years.
- SME expects a yearly turnover increase of €1 million within 5 years.

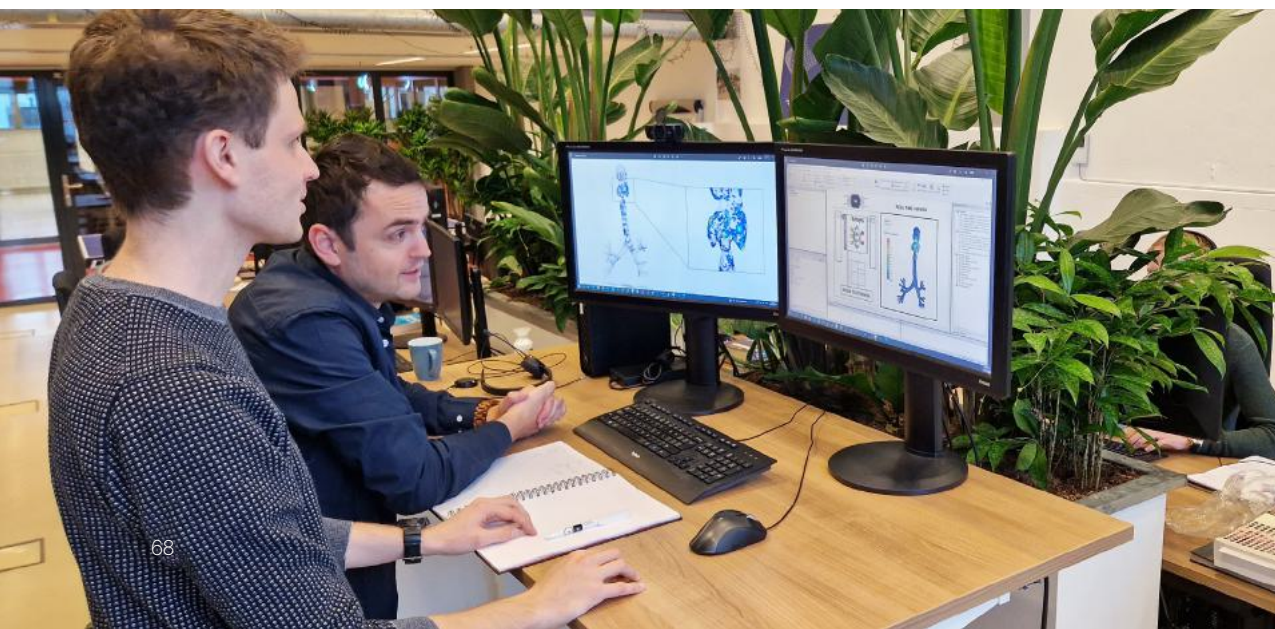



AI-Platform for Automated Training of Object Detection Models Based on CAD Data

Organizations

Gabler Engineering GmbH is a production SME working in the design and manufacturing of production machines, especially confectionery machines and pharma production lines. **Kimoknow UG** is an expert in object detection with cameras, based on deep learning models. **SolidLine GmbH** is a sales and engineering company for CAD products from Dassault Systèmes. The company is an expert in 3D CAD software, CAD model databases, and product lifecycle management solutions. **Karlsruher Institute of Technology** is one of the biggest science institutions in Europe and owns HPC infrastructure.

End User Technology Expert & End User Domain Expert & Tech Distributor HPC Center

The Challenge

The manual assembly of devices consisting of many individual parts is a time-consuming, tedious and error-prone industrial process, which could be supported by automated recognition technologies. Currently, only a few specific industrial applications such as autonomous robots or mass production quality control can benefit. Applications such as warehouse part detection, where one is dealing with thousands of individual parts, are still not economically feasible. The part identification process could be assisted through automated object detection within an Augmented Reality (AR) application which outputs a list of potential candidates that limits the number of objects to check.



Industry Sector:
Manufacturing
Technology used:
HPC, AI, ML

Find out more



The Solution

To make object detection for large datasets of industrial parts possible, Kimoknow maximized the automation of AI training. The approach for automatic AI training entails generating synthetic images from 3D CAD data and then using datasets to train an object recognition model. The solution is service-based and can be scaled modularly to available computing resources. The reduced time to generate an AI model allows very quick delivery to a customer and fast, cost-effective fine-tuning of the results.

The Impact

End-users of the Kimoknow AI detection system can enable their staff to be more efficient and to work in increasingly complex environments. Therefore, jobs can be preserved as staff becomes more effective, and workers can be hired to do difficult tasks without extensive training. The infrastructure built during the experiment provides Kimoknow with a business model that is highly scalable and can be backed by a cost-effective and energy-efficient HPC backend for the batched creation of fine-tuned object detection models in reduced time. This serves the long-term business goal of Kimoknow to provide object detection services, where users can easily train object detection models based on their CAD data. Production and logistics companies such as Gabler Engineering benefit from Kimoknow services as they can generate object detection models for their own data with very low manual effort and implement object detection applications much more cost-effectively, thus creating AR tools to substantially improve their processes. Companies that are new to AI-object detection can see results for their own use cases and therefore the entry barriers to new applications are significantly lowered.

Benefits

- Reduction of manual effort from more than 800 hours to less than 10 minutes for generation of an AI model of more than 1,000 parts.
- Kimoknow can offer AI applications previously economically unfeasible.
- Kimoknow is able to provide services to thousands of customers at once.
- Gabler can save several work hours each day through reduced search times, resulting in higher productivity and quality.



Multiphysics and Multiscale Modelling of Aeronautical Components



Industry Sector:
Manufacturing
Technology used:
HPC, FEM
Simulation

Organizations

Manta Group is an Italian SME that operates in the aeronautical field and specializes in the production of composite aircraft parts.

CETMA is the technology expert, a private Research and Technology organization, which has acquired skills and know-how focused on composite materials and numerical modelling of these advanced materials and their manufacturing processes.

CINECA is the largest Italian HPC centre and cooperates with academia and industrial partners.

End User



Technology Expert



HPC Centre & Provider



CINECA is part of the Italian NCC.



The Challenge

Autoclave moulding is the main fabrication method for composites used in the aerospace field. Working with innovative materials and geometries and (or together with) the rising mechanical stresses during the curing process lead to an increased number of defects and voids in the finished components which then are rejected. During the curing process, the mechanical stresses in the various materials rise. Currently, an expensive trial-and-error approach is used to find the optimal process parameters to produce complex-shaped components while minimizing the risk of voids or geometric distortions, which leads to long development times and high costs.

The Solution

To optimize the autoclave process parameters, the different phenomena during the curing process need to be simulated to predict the parameters' effects on the quality of the components to be manufactured. To this end, two separate multiphysics and multiscale numerical models were set up and validated. Using the material properties, the lamination sequence, the geometry of the parts, and the specification of the autoclave curing cycle as input parameters, the HPC simulations proved to be able to provide the required information about the resulting part distortion and possible defects in the finished part in a very short amount of time.

The Impact

Thanks to this simulation experiment called MULCOM, MANTA now uses HPC-based simulations to produce high-quality composite components, reducing development time and costs while increasing its competitiveness. Since autoclave moulding will remain the main manufacturing technology of aerospace structures at least for the next 10 years, this significantly strengthens Manta Group's business position. In addition, the improved autoclave process know-how can enable MANTA to profitably enter many other sectors besides aerospace (e.g. luxury boats, automotive, sport). All this helps to attract new customers by offering a full service, from design to the production of the component. The expected business impact has been quantified at €1million three years after the end of the experiment.

Benefits

- MANTA: Design costs reduced by up to 50% (about €100k saving per year), material waste by 70% (about €60k saving per year), and raw materials usage by 15% (about €150k saving per year).
- CETMA: expects to join new R&D projects and consultancy services with an increase in its revenue of about €50k per year.
- CINECA aims to become MANTA's provider of HPC resources estimating its related increased revenue to €20k per year.

Find out more





Multi-Head Additive Manufacturing with Optimal HPC Thermal Stabilization

Organizations

Mikrotvornica Ltd. is a Croatian SME that has extensive experience with different additive and digital manufacturing technologies and sells 3D printers.

Ruder Bošković Institute is regarded as Croatia's leading scientific institute in the natural and biomedical sciences as well as marine and environmental research.



End User



HPC Expert



Ruder Bošković Institute is part of the Croatian NCC.



The Challenge

When using industrial machines for additive manufacturing, heat and its dissipation to individual structural elements of the machine play a major role. A heated workspace inside a 3D printer is important because most materials used in industry require heated work chambers to work with. Problems with the heat distribution inside the 3D printer can lead to void formation, geometrical deformation or poor interlayer bonding in the printed pieces. Mikrotvornica's aim was to understand what effect temperature distribution and different possibilities for generating a high temperature inside the chamber have on the printer itself and on the final 3D-printed pieces.

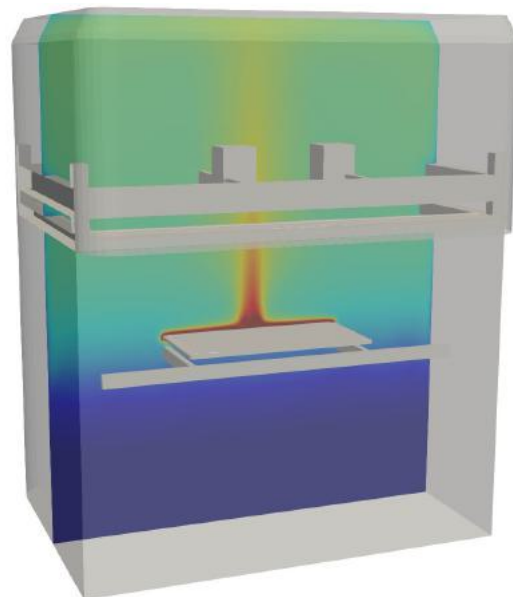

Industry Sector:
Manufacturing
Technology used:
HPC, CFD
Simulation

Find out more



The Solution

The impact of heat on the structure and motion system of the 3D printer was predicted using a numerical simulation model for the 3D printer. The 3D geometry files for the different parts were generated and boundary conditions and material parameters were set up. Simulations were performed incorporating the unsteady process while the printer chamber heats up and different parts move. The CFD had a run time of 3-4 days and could be used in the development and production process of new machines or to find the correct temperature setting. Several tests on 3D printers were performed to validate the numerical simulations. During tests, the exact temperature values inside the chamber were measured and compared with the results of the numerical simulations.

The Impact

By using HPC and numerical simulations, delivery times can be shortened significantly by 30-50% leading to a reduction of 15-30% in production costs. This amounts to savings of €150k over a period of three years. Through the usage of numerical simulations, the accuracy of the 3D printing process is increased and Mikrotvornica can be more competitive on the market with the improved 3D printers. Therefore, it is possible for Mikrotvornica to achieve an increase in sales by 20-30% which can generate €600k more in revenue over a period of 3 years. By using simulations in development and production Mikrotvornica will create jobs for new highly skilled employees, in order to generate even better results in the future.

Benefits

- Shortening of product delivery time to the customer by 30-50%.
- Cutting costs in production by 15-30%.
- Greater accuracy of 3D printers expected to increase sales by 20-30%.
- Creation of jobs for new highly skilled employees performing simulations for even better results.



Topology Optimization of Micro-Channel Heat Exchangers

Organizations

Aidro is an Italian high-tech SME specialized in the design and manufacturing of hydraulic parts and metal devices by both traditional technologies and Additive Manufacturing. **OPTIMAD** was founded in 2006 as a Spin-Off company of the Department of Mechanical and Aerospace Engineering of the Politecnico di Torino and is specialized in the development of numerical simulation codes for scientific computing. **CINECA** is the largest Italian HPC centre and cooperates with academia and industrial partners.



End User



ISV



HPC Centre & Provider



CINECA is part of the Italian NCC.



The Challenge

The design of Micro Channel Heat Exchangers (MCHX) requires balancing many competing design constraints, including weight reduction and manufacturability. Topology Optimization (TO) is a promising design paradigm for finding an optimal design that meets all requirements. However, geometries resulting from TO are impossible to manufacture using standard techniques. Instead, the design and production paradigm of combining TO with Additive Manufacturing has enormous potential but requires the solution of key technical challenges to provide accurate results at speeds consistent with industrial design cycles.

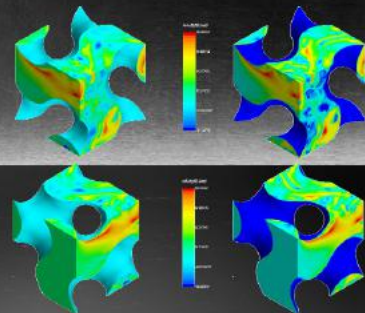
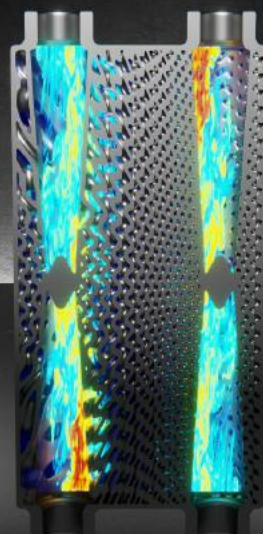
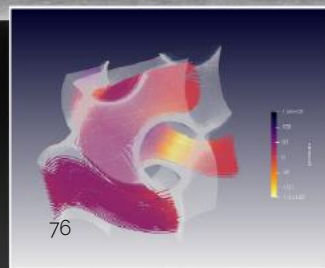
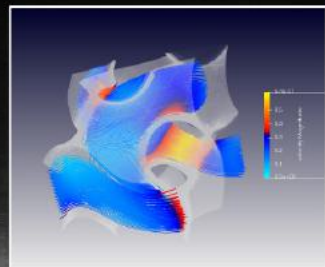

Database of microscopic simulations for ML model training

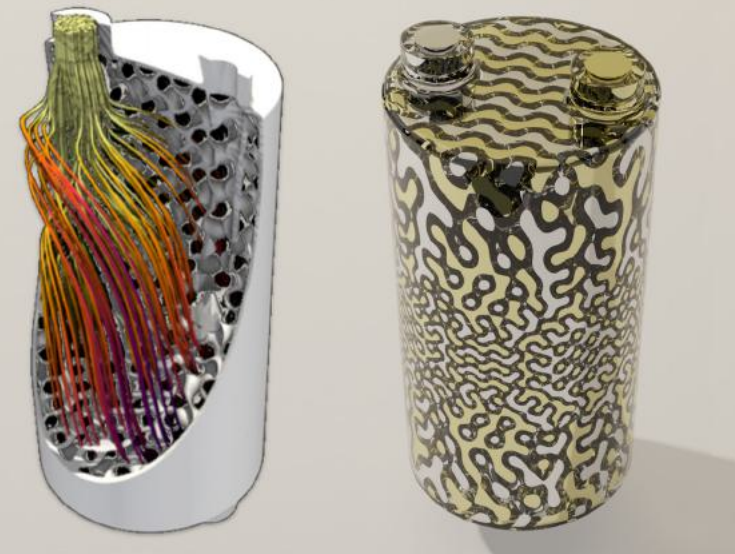

Industry Sector:
Manufacturing
Technology used:
HPC, CFD
Simulation

Find out more



The Solution

The TOLOMHE platform was conceptualized and developed as a SaaS platform, which integrates a set of computational tools for topology optimization of MCHX in an HPC-centric framework. TOLOMHE represents the first step towards cloud services for topology optimization methods and generative design offered to SMEs specialized in AM for MCHX. An innovative solution is based on coupling a standard CFD solver, an ML model and a parametrized topology. Thanks to the synergic deployment of the ML model and the CFD solver, multiscale CHT simulations can be performed without the burden of simulating high-resolution models during the online phase.

The Impact

TOLOMHE represents an easy-to-use platform for generative design and product optimization. The ultimate goal is to alleviate problems and barriers encountered by SMEs specialized in the design of high-performance MCHX. TOLOMHE has the potential to become a technology enabler and will allow a user to target high-value applications, improve the design of existing products, and ultimately increase market competitiveness. Thanks to the adoption of TOLOMHE, the end-users are expected to accelerate the transition from a build-to-print to a build-to-spec business model by reducing R&D costs and time-to-market for new products.

The first applications at Aidro foreseen for the TOLOMHE platform are an oil-air heat exchanger project for the transmission system of helicopters, and a sea water-natural gas heat exchanger project for off-shore gas platforms.

Benefits

- Automation of the design workflow has the potential to reduce time-to-design by 75%, time-to-market by 50%, and time-to-prototype by 90%.
- Aidro: End-user savings can potentially add up to €100k by redirecting skilled labor to other added-value activities.
- OPTIMAD: TOLOMHE can generate a stream of revenue of approx. €250k-500k in the first 36 months.
- CINECA: Sales of CPU cycles can generate up to €40k per year.



Multi-Phase Modelling of Nanofluid Hydronic System

Organizations

TCT S.r.L. is an Italian SME that has been developing nanomaterials and invented and patented a nanofluid "HTF Compact" for the purpose of improving heat transfer efficiency according to customer needs. CETMA is a private research and technology organization that has acquired skills and know-how focused on numerical modelling of complex phenomena. CINECA is the largest Italian HPC centre and cooperates with academia and industrial partners.



End User



Technology Expert



HPC Provider



CINECA is part of the Italian NCC.



The Challenge

HTF Compact (a dispersion of solid metal oxide nanoparticles in a base fluid), drastically improves heat transfer in hydronic systems for thermal management. However, the performance is dependent on many parameters, such as material and concentration, for optimal nanofluid design. To better understand the nanofluids' performance, CFD simulation is used to avoid an expensive trial-and-error approach. CFD tools for efficiently simulating a nanofluid and the manufacturing process must meet TCT's business constraints.

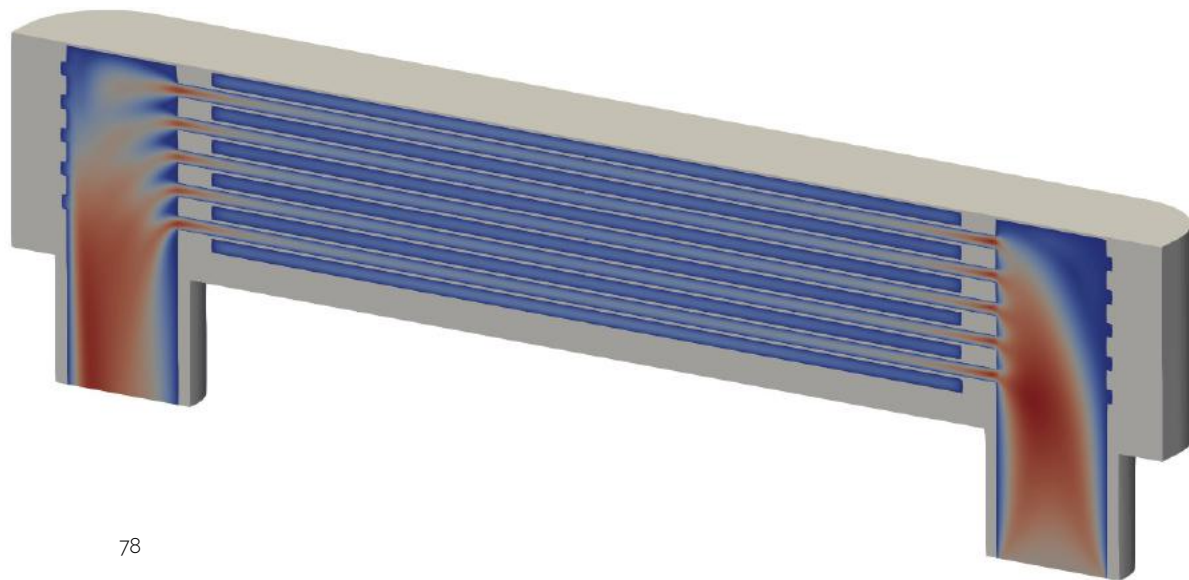

Industry Sector:
Manufacturing
Technology used:
HPC, CFD
Simulation

Find out more



The Solution

The use of HPC is essential to simulating the performance of nanofluids, with their large numbers of nanoparticles, and their impact on the hydronic system. Furthermore, HPC is necessary to create a mesh fine enough for accurate and reliable results. Such numerical models would take up to several weeks to compute on in-house workstations. Using HPC allows us to drastically reduce the computational time to a few hours and thereby minimize the necessary number of physical tests and associated waste.

The Impact

The innovative technology created in the "HYSY" experiment has allowed TCT to improve its current design and production, abandoning the trial-and-error approach. TCT will use the HPC-based simulations to reduce both time and costs needed to produce high-quality nanofluids thereby increasing its competitiveness. All these aspects can have an important impact on the market and could bring new business developments on a European and global scale. The expected business impact has been quantified at €1M three years after HYSY's end. In all hydronic systems, adding nanoparticles into a base fluid (water or glycol/water) can increase the thermal conductivity and heat transfer coefficients. This has a positive environmental impact, reducing CO2 emissions and electricity usage by up to 25%. With such improved heat transfer, new designs can generate further savings by reducing the size of heat exchangers and systems in general.

Benefits

- TCT: time-to-market reduced by 66%, material waste by 70%, and energy power by 15%.
- CETMA expects new R&D projects and consultancy services, an increase in revenue of about €50,000 per year.
- CINECA aims to become a provider of HPC resources to TCT at an estimated €20,000 per year.



HPC-based Hand Gesture Dataset Generation for Detection and Tracking

Organizations

Youbiquo is an Innovative SME specialized in Artificial Intelligence, Computer Vision, and Machine Learning applied to Augmented Reality wearable electronic devices.

BI-REX is one of the 8 Italian Competence Centres with a specific focus on Big Data, innovation processes, and the adoption of enabling technologies.

CINECA is the largest Italian HPC centre and cooperates with academia and industrial partners.



End User



Domain Expert



HPC Provider



Bi-rex & Cineca are part of the Italian NCC.



The Challenge

Hand tracking and gesture recognition are critical components of Augmented Reality technology as they allow users to interact with virtual objects in a natural and intuitive way. To make hand tracking and gesture recognition truly seamless, two main challenges need to be addressed. The first challenge is latency reduction. The second one is the accuracy and robustness of detecting hand gestures in different scenarios in the shortest time.



Industry Sector:
Manufacturing
Technology used:
HPC, AI, ML

Find out more



The Solution

The solution developed in the experiment called "HandyTrack" improves the performance of hand gesture detection and tracking algorithms by using HPC to train deep learning. The use of HPC allows our solution to reduce the time required for training algorithms and generating larger, more diverse datasets. This leads to improved accuracy and robustness of hand gesture detection and tracking algorithms and provides unlimited dynamic gesture recognition that is calibrated to the detection of both hands at the same time.

The Impact

This experiment will have a strong business impact on the profitability of a software library for hand gesture recognition and tracking based on dataset and training produced with HPC. It offers a higher level of accuracy in hand gesture detection in less time, which is an improvement on the state of the art represented by the main competitors. The overall result will be embedded both in a standalone software library bundled in wearable electronic devices and in a high-performance cloud-based application. Moreover, reducing the time required for training and generating more realistic and diverse datasets gives HandyTrack the potential to significantly advance the field of touchless interaction and make hand gesture-based interfaces a reality. The designed solution has a human-centered vision and consequent social impact increasing inclusivity and diversity. For example, the generation of unlimited customized hand gesture datasets can be used to support people with disabilities in their interactions with non-disabled persons and machines as in the case of people who are deaf mute.

Benefits

- Improved training time: Up to 80% reduction of training time for neural networks.
- Reduced cost of generating custom hand gestures by 99.6%.
- Natural user experience: Ability to switch from a static to a dynamic hand gesture model.
- Enhanced capability: Creation of an unlimited hand gesture dataset.
- New opportunities: Address previously untapped domains and market segments.



Forecasting Reliability in Manufacturing

Organizations

KLS Ljubno is a Slovenian SME that is a leader in the production of rings for vehicle engine flywheels. **MaTec Gummiwerk** is a German SME that manufactures individual high-tech products in the field of technical rubber parts. The Austrian-German **Pumacy Group** is a specialist in Applied Knowledge Processing in manufacturing. Its Plexalytics system supports customers in machinery, renewables, and automotive industries.

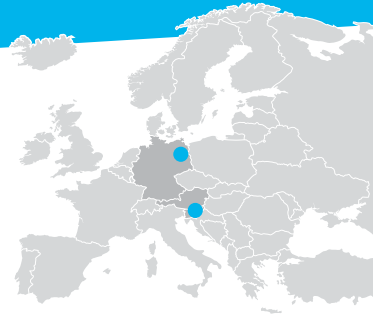

End Users



Technology Expert & HPC Provider



The Challenge

Identifying production errors early is crucial for medium-sized part suppliers to avoid warranty costs and maintain customer trust. Reliability - consistent product functionality over time - is the key characteristic to measure and improve in this regard. However, both small-sized manufacturers and mass producers face challenges in collecting and analysing reliability data, requiring extensive storage space and high computing power.

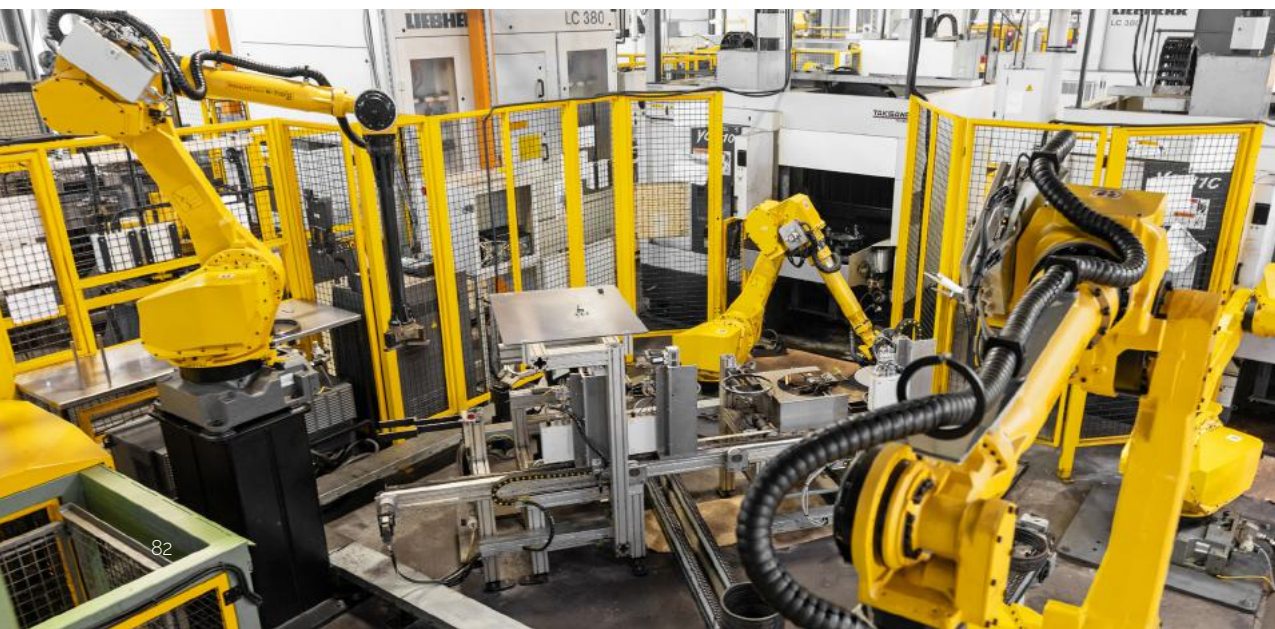

Industry Sector:
Manufacturing
Technology used:
HPC

Find out more



The Solution

Using the Plexalytics SaaS platform, the experiment developed HiPerRel, a solution to improve the reliability of metal and rubber parts manufacturers by collecting more data from machines. Since SMEs lack their own data centres, an external High-Performance Computing centre is integrated to check and apply measures for enhanced reliability and reduced failure probability. HiPerRel provides overnight reliability information and allows immediate production parameter adjustments if needed.

The Impact

The connection of the Plexalytics Search Based Application platform to the HPC architecture provides the first business model with which not only large corporations but also small to medium-sized series manufacturers can be served. The result of the experiment helps small to medium metal and rubber parts manufacturers recognize errors and their influence in a very early phase of the production process, statistically check and apply the relevant mitigation measures to increase the reliability of the products, and reduce the probability of failures. KLS and MaTec will experience substantial future gains as a result of these advancements, leading to improved reliability of their parts and, consequently, increased customer satisfaction. The capacity for early calculation of reliability reduces the number of failed parts. This not only improves the quality assurances of the manufacturer SMEs, but also achieves substantial savings in material and energy resources at the same time, which contributes to carbon reduction and improved use of natural resources.

Benefits

- Reduction of the evaluation of parts reliability to one night instead of 8 days.
- Due to early failure detection, KLS and MaTec report a 15% reduction of long-term failure rate.
- Improved reliability prediction models will lead to a 25% growth of Pumacy's customer base in three years.



Cloud-Based CFD Optimization of Magnetic Drive Pumps using HPC

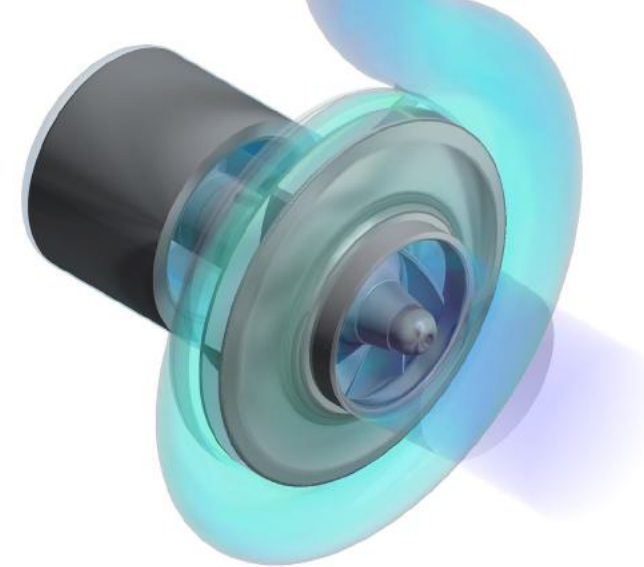

Industry Sector:
Manufacturing
Technology used:
HPC, CFD

Organizations

CDR Pompe s.r.l. is an Italian manufacturing SME, a leading developer and producer of pumps for hazardous, corrosive, and highly pure liquids in the chemical, pharmaceutical, and other process industries. **EnginSoft** is a consulting SME specialized in the field of Computer-Aided-Engineering with offices worldwide. **CINECA** is the largest Italian HPC centre and cooperates with academia and industrial partners.



CINECA is part of the Italian NCC.



The Challenge

Magnetic drive chemical-process pumps eliminate the need for shaft sealing, reducing costs and improving safety by avoiding leakage of hazardous fluids. CDR desired to re-design and optimise four sizes of this kind of pump to improve performance, reduce engineering and manufacturing costs, and comply with regulations of markets outside Europe. However, the simulation tools, know-how, and HPC infrastructure required were not available to CDR.

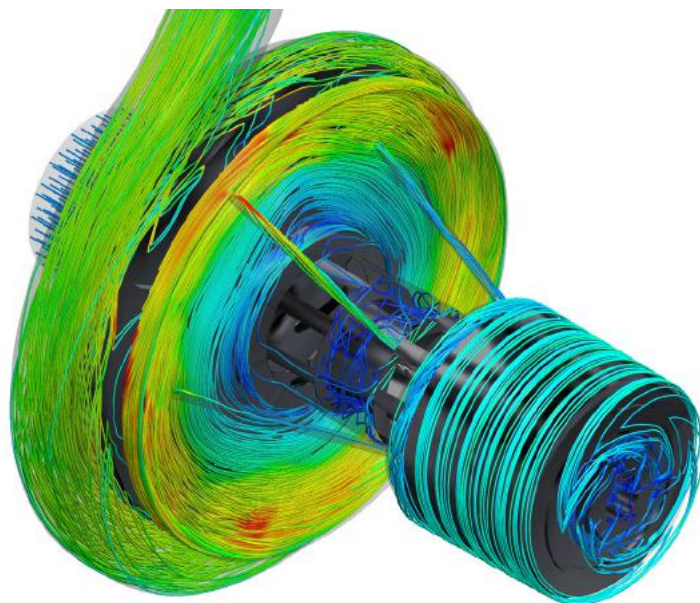

Find out more



The Solution

CDR teamed up with EnginSoft to optimise the four pump sizes using CFD. The CFD models use a mesh with 30-70M elements and a steady-state approach. The subsequent geometry-based optimisation process (based on the Design of Experiment and Response Surface methodology) provided optimised performance maps in terms of head, efficiency, power and axial thrust (reduced by 5-20%, permitting longer pump lifetime). In total 130,000 core hours were used to investigate more than 80 design points for each pump size.

The Impact

Besides making CDR more competitive in the European market, the improved models will help to access the US market (being compliant with the local standards), with expected growth in the company's annual turnover of EUR 1.5M after five years. The reduced maintenance need is a game changer for an SME with no maintenance support force in the US and a competitive asset in such a complex market. The HPC-based design process cuts down time-to-market by 50%. To strengthen the contribution of these tools to future business, the SME doubled the number of simulation and product design experts in the R&D team. EnginSoft built relevant know-how regarding services, software sales, HPC consultancy, and training courses related to the pump market and to complementary market sectors. Reduced energy consumption also leads to reduced CO2 emissions. A better design for a magnetic drive pump prevents fluid dispersion, reducing noise and vibration, and increasing the versatility, reliability, and durability of the pump, while requiring less planned and unplanned downtime and maintenance.

Benefits

- Substantially improved energy efficiency, lifetime, and robustness of CDR's magnetic pump models.
- Improvements enable access to the US market (USD 12 Billion in 2021 in total) for CDR.
- EUR 1.5M additional annual turnover expected after 5 years for CDR.
- EUR 1.5M additional turnover in the pump design sector expected for EnginSoft in the next 3 years.



Improvement of Graphene-Epoxy Based Composite Materials Production Through HPC

Organizations

Nanografi is a manufacturer and supplier of advanced nanomaterials with one of Europe's largest graphene production plants. **Alti Dynamics** is an SME focusing on advanced aerospace, nanomaterial technologies. **Middle East Technical University (METU)** is a Turkish public university that provides HPC expertise. **TUBITAK ULAKBIM** is a Turkish national centre providing HPC and data storage to academia and industry.



End User



Technology Expert



HPC Expert



HPC Center



TUBITAK & METU are part of the Turkish NCC.



The Challenge

Some of the most popular products of Nanografi are nano-sized graphene and graphene oxide (GO)-enhanced polymer composites. Together with Alti Dynamics, they try to find the optimal composite properties (e.g. the dispersion of graphene layers) by an expensive trial-and-error experiment-based approach which does not always provide the necessary insights. The challenge is to replace this time-consuming and costly process with HPC simulations.

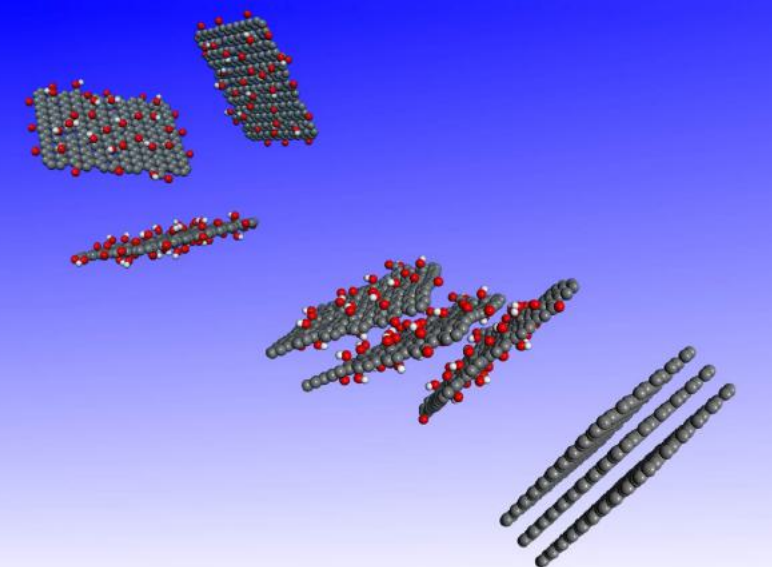

Industry Sector:
Manufacturing
Technology used:
MD Simulations,
Monte Carlo
Simulations, HPC

Find out more



The Solution

The types and number of functional groups on GO, the mass percentage of GO in the resin matrix, and the structure of the epoxy resin were optimized with HPC simulations. The materials were manufactured, tested for material properties and simultaneously modelled by the HPC experts. With classical molecular dynamics simulations, which due to the size of the systems and level of interaction required HPC, strong candidates for the actual synthesis stage have been identified.

The Impact

Thanks to this experiment, Alti Dynamics is able to reduce the development time for new high-quality epoxy-graphene nanocomposite materials by up to 15 % and the costs by up to 20%. Employing the new HPC workflow, new materials with improved properties can be designed and produced on a large scale with very high accuracy. The companies expect to reduce testing material waste by 75% (approx. €260,000 savings per year) and raw material consumption by 40% (approx. €315,000 savings per year). The new HPC-based workflow will provide Alti Dynamics with a competitive advantage and a corresponding increase in revenue expected to add up to €750,000 during the next 3-4 years. Nanografi will be able to sell significantly more raw graphene products to customers, especially automotive and aerospace companies, because of the optimisation provided by Alti Dynamics. As a result of the experiment, graphene will gain a stronger foothold in the composites market as a mechanical performance-enhancing and weight-reducing additive, both of which are highly desired properties for aerospace applications.

Benefits

- Alti Dynamics expects to save over €260,000 per year because fewer tests are necessary.
- Alti Dynamics expects an increase in revenue up to €750,000 during the next 3-4 years.
- Within 3 years, Nanografi expects to increase sales of graphene-related products by a factor of 10.



HPC Simulation of Metal Powder Segregation in the Manufacturing of Cored Wire

Organizations

CEDIE is a Spanish manufacturing SME that produces more than 10,000 tons of cored wire filled with metal powders per year specially designed for steel mills and foundries.
GOMPUTE is a Swedish simulation and HPC solution provider.
CITMaga is a Galician center for research and technology transfer in the field of Industrial Mathematics that supports industry and organizations.



End User



Domain Expert



HPC Provider



The Challenge

Cored wires manufactured by CEDIE are used in the steel and foundry industries. The cored wire quality is of the utmost importance and the required quality can be lost through undesirable segregation between different metal particles during the wire filling process. On average, an annual 1.5% of the coils' length is rejected because of a lack of uniformity. This leads to inefficiencies in the production, generation of material waste and, consequently, high economic losses.

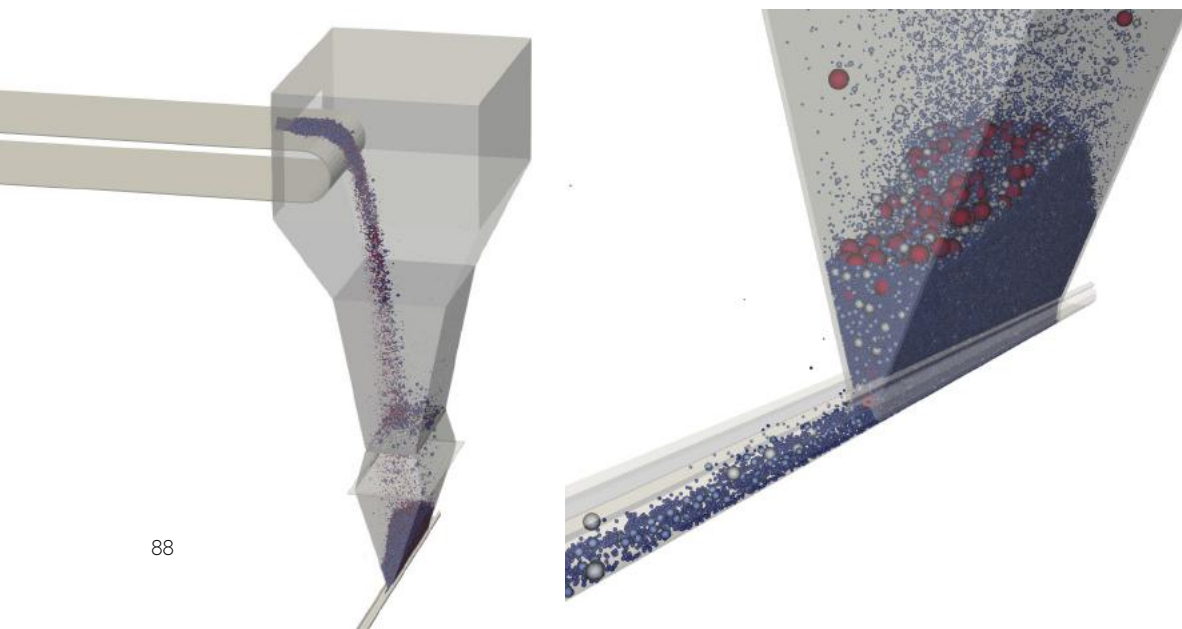

Industry Sector:
Manufacturing
Technology used:
HPC, DEM
Simulations

Find out more



The Solution

The Discrete Element Method (DEM) – implemented by CITMAGA with open-source code - was used to predict the segregation during the initial production stage of the cored wire. The material parameters were calibrated via studies performed for granular flows in simplified configurations. The model has been validated against experimental measurements obtained during production. Since DEM simulations require a huge computational effort, execution on HPC resources, provided by GOMPUTE, is essential.

The Impact

The experiment enables CEDIE to improve the manufacturing process of cored wire by reducing deficiencies. Savings in material waste are estimated to be 90%, resulting in an estimated cost reduction of up to €375,000. In practical terms it provides a detailed understanding of the process, opening a window for exploring new designs for bins and conveyor layouts as well as new types of mixtures in the medium term. Thus, CEDIE's competitiveness will increase by developing new products before competitors as well as maintaining cost-efficient and more eco-friendly production. These business levers determine the framework for assuring its sustainability. For CITMaga and GOMPUTE, knowledge gained from the experiment is valuable for consulting projects regarding DEM simulations in other industrial sectors. CEDIE is located far from high-density industrial regions and from the centre of gravity of steel and foundry production in Europe. Despite this being a strong drawback, the experiment contributes to sustaining and consolidating highly qualified employment in depopulated regions.

Benefits

- 90% reduced material waste leads to an increase in profit for CEDIE of up to €337,500 over 4 years.
- CEDIE has a tool to increase the intrinsic quality of its products and its competitiveness.
- CITMaga expects revenues of €30,000 per year by applying DEM know-how to other industrial sectors.
- GOMPUTE expects revenues of €20,000 per year with new customers in the field of HPC DEM simulation.



High Performance Computing for Profile Extrusion

Organizations

Soprefa is a Portuguese SME specialized in the production and distribution of plastic profiles for a large variety of applications. **Wolf Dynamics** is an Italian SME specialized in consulting services in computer-aided engineering (CAE), multi-physics simulations, numerical optimization, data analytics, and interactive data visualization. **University of Minho** has more than 20 years of experience in the field of profile extrusion, with expertise in HPC.



End User



ISV



Technology & HPC Expert



University of Minho is part of the Portuguese NCC.

The Challenge

Plastic profiles are widely used in various sectors due to their competitive properties and design flexibility. However, their trial-and-error-based design approach, dependence on designer experience, and high material and time requirements hinder development, increasing costs for Soprefa. To address this, a simulation framework is needed to enhance the design process, reduce costs, and deliver higher-quality profiles within industry timeframes.

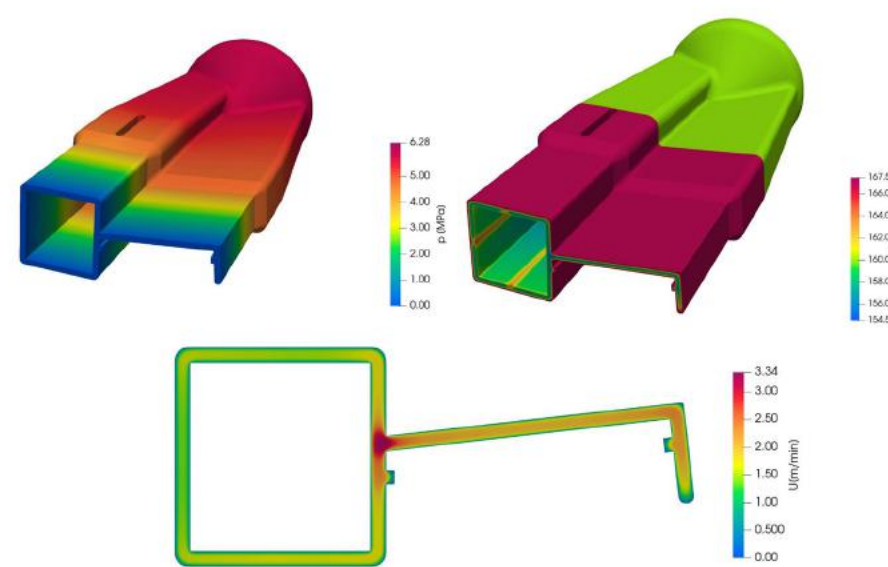
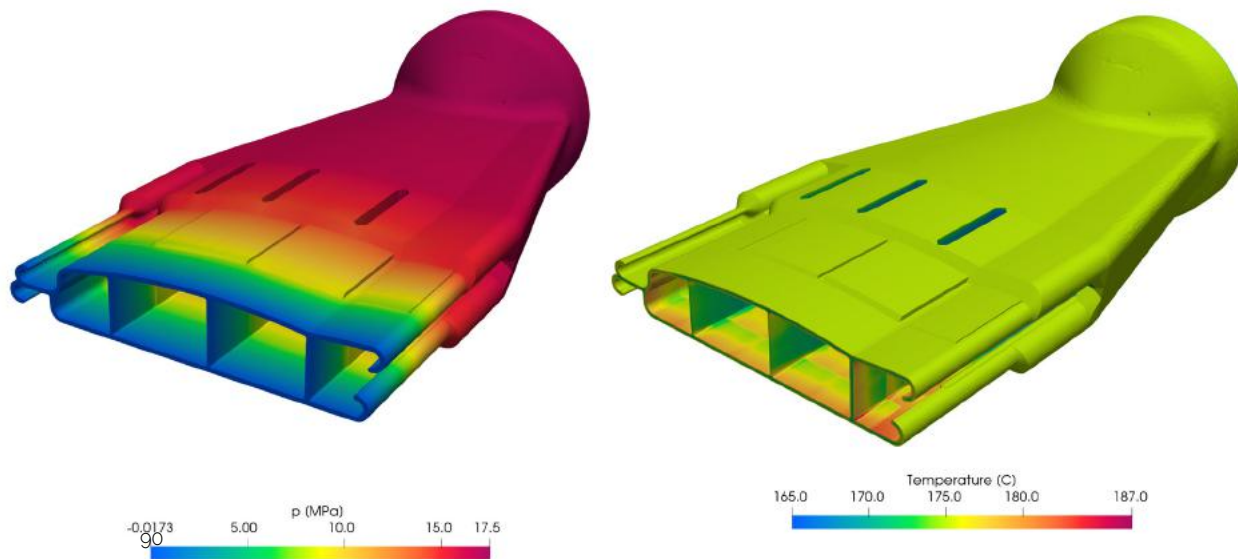

Industry Sector:
Manufacturing
Technology used:
HPC, CFD Simulations

Find out more



The Solution

The simulation framework developed uses the open-source CFD library OpenFOAM coupled with the optimization software Dakota. This allowed the extrusion die to be optimized by conducting hundreds of simulated trials per day, an impossibility without HPC. Two different CAD packages were used, Onshape and Fusion 360. Methods were implemented to ensure the correct interaction between the CAD software and the HPC system. The framework was tested both by improving old extrusion dies and by testing new ones.

The Impact

The results of the experiment clearly show the advantages in terms of product time to market (30-40% reduction) and cost (23% reduction) of using computational modelling on HPC. Soprefa now has access to a simulation framework that can support its development process, which will allow for an increase in the number, range, and complexity of their products and, hence, client base. The University of Minho and Wolf Dynamics demonstrated the effectiveness of their know-how for addressing industrial problems. The approach was clearly innovative and allowed them to solve unforeseen issues like the need for permanent communication between CAD and simulations/optimization tools that run in different environments. The results obtained emphasized the joint skills of the University of Minho and Wolf Dynamics and allowed the latter to expand their knowledge in the field of polymer processing. The capabilities acquired in the experiment by both partners will promote their participation in additional projects where the developed framework can be adapted to applications other than plastic profile extrusion.

Benefits

- A novel design methodology for profile extrusion dies exploiting the speedup offered by HPC.
- Reduction of 30-40% in the product time to market.
- Minimum Reduction of 40% of raw materials used in experimental trials.
- Reduction of the overall cost development by 23%.



Boosting CFD Simulation of Thermal Equipment for Food Processing

Organizations

TACORE is a Spanish industrial manufacturing SME specialized in canning technologies. **SDEA Engineering** is a Spanish consultancy SME specialized in mathematical modelling. **ANFACO** is a Spanish private non-profit business association in the marine and food industry. **FEUP** is the Mechanical Engineering Department of the University of Porto. **CESGA** is a public foundation that provides HPC services.



Industry Sector:
Manufacturing
Technology used:
HPC, CFD
Simulations

Find out more



The Challenge

The canning industry in Europe, particularly in Spain and Portugal, is economically valuable. Thermal sterilization in autoclaves for canned food is energy-demanding and its improvement can reduce energy consumption and CO₂ emissions, resulting in cost savings. Specialized personnel are needed for fluid-thermal simulation engineering. The challenge is to develop a specialized tool using HPC, offering new competencies and opportunities for companies.



The Solution

An easy-to-use tool was developed for simulating thermal sterilization in autoclaves, eliminating the need for general calculation tools and highly qualified personnel. The tool is a complete SaaS including HPC resources offered as a subscription service. The solution consists of the simulation with OpenFOAM and a WEB GUI interface. The use of HPC allows users to carry out simulations in more detail and in less time (5-15 minutes per simulation) enabling them to investigate different design options.

The Impact

TACORE will have a market advantage with more efficient and customizable manufacturing. The cost reduction to develop an autoclave will facilitate the substitution of obsolete equipment leading to yearly savings of €40,000. Two customers of SDEA in the automotive industry are interested in similar simulation tools. These opportunities involve the incorporation of a specialized profile for the development and support of SaaS. Furthermore, the experiment simulations and analysis will provide detailed information on a machine's energy consumption and detect if it is possible and worthwhile to intervene to reduce it, achieving a smaller carbon footprint. FEUP will present the tool to students as a showcase for possible energy optimization applications. They can use this tool to gain knowledge about CO₂ emission savings. FEUP can also present the tool to companies. For ANFACO, this is an opportunity to offer the new tool: the industries that apply this new service in their production processes will face a business benefit, in terms of their energy savings and reduction of CO₂ emissions.

Benefits

- TACORE estimates a reduction in production costs of 23% in the cost of an autoclave and brings an annual benefit of 2.7% in the annual turnover.
- For ANFACO members, a 2% improvement in efficiency saves 0.00187592 tCO₂/tonne of product.
- SDEA estimates an annual revenue of €40,000-60,000 for the development of custom applications.



A High-Fidelity Tool for the Optimal Design of Wind Assisted Propulsion Technology

Organizations

AYRO is a French SME that designs, manufactures and delivers the wind propulsion system Oceanwings®. ToolsPole is an Estonian SME that develops the software BREVA for the automation of design workflows. Università della Svizzera Italiana is a public university in Switzerland and Politecnico di Milano is the largest scientific-technological university in Italy. CINECA is the largest Italian HPC centre and cooperates with academia and industrial partners.



Industry Sector:
Maritime
Technology used:
HPC, CFD
Simulation

Find out more



End User



Domain Experts



HPC Provider



CINECA is part of the Italian NCC.



The Challenge

AYRO has created Oceanwings®, a rigid wing technology, consisting of a two-element articulated wingsail that generates forward thrust through aerodynamic lift. It is controlled by automated AI software for optimizing the wing's angle of attack and camber in real time to maximize thrust and save up to 50% of a ship's fuel consumption. AYRO aims to further optimize the design of the sail, adapt it to different ships, and to improve the control software.

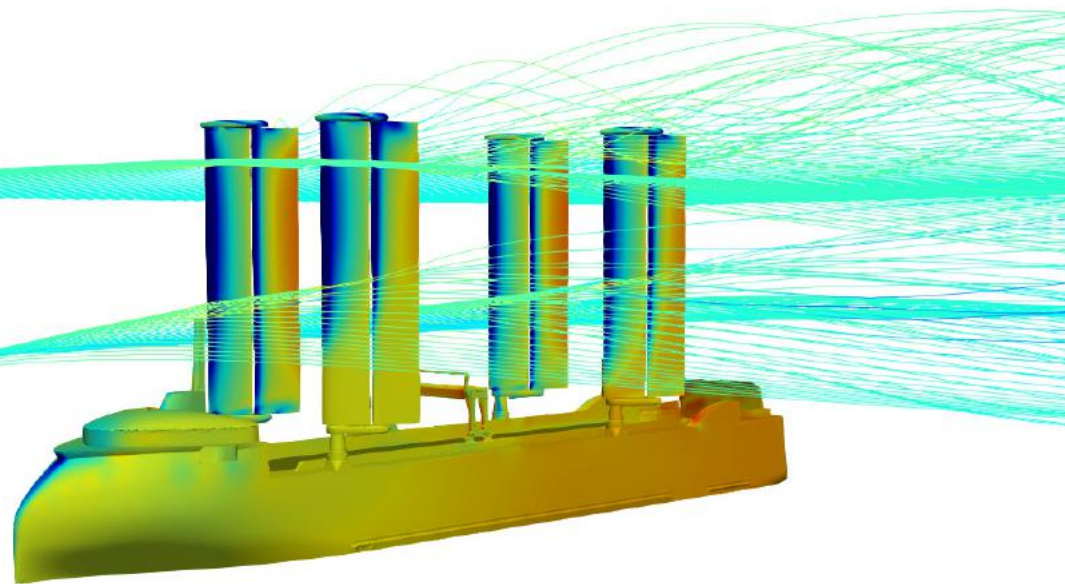

The Solution

PoliMi, AYRO, and CINECA developed a robust and easy-to-use tool to automatically launch OpenFOAM CFD simulations on HPC systems. Simulation results are included in ToolsPole's BREVA software environment, which, based on a Bayesian optimizer developed by USI, finds the best trim of the wings with respect to optimal thrust, thereby providing information about optimal design of the wings and – at the same time - generating large databases to feed the AI-based control software.

The Impact

The experiment set up an HPC-based automated toolchain and workflow for extensive high-fidelity simulations and optimizations at an affordable cost with competitive time-to-solution that produces excellent results, which benefit AYRO as follows:

- Improved performance of the AI on-board wing sail control software leads to higher fuel savings and thereby to follow-up business with existing customers willing to pay for algorithm upgrades.
- Improved design and thereby aerodynamic performance make Oceanwings® more competitive in terms of price/performance. A 10% increase in performance is possible with these new products with margins yet to explore for improvements.
- Easier generation of adaptive configurations allows AYRO to now make competitive offers for a variety of ships.
- Automation of the design workflow and use of open-source code speeds up the development process by a factor of 3 by allowing simultaneous computations without incurring prohibitive license costs.
- With improved designs and control software CO2 emissions can be further reduced.

Benefits

- AYRO expects an additional annual turnover of €300,000 due to the improved control software.
- Wingsails-related turnover is projected to increase by 300% by 2030.
- ToolsPole will increase its sales by up to €40,000 annually due to improved technology toolchains.
- CINECA could gain additional business as an HPC supplier for approx. €20,000 per year.



High-Performance Computing for High-Value Weather Forecasts

Organizations

Aslogic is a Spanish Engineering SME that develops and co-creates solutions for highly efficient and safe air traffic management.

University of Leon is an expert in developing numerical weather forecast models for the aeronautical sector. It has been a technology supplier for the Spanish National Institute of Aeronautical Technology for over 25 years.

CESGA is a public foundation that provides HPC services for R&D, supporting SMEs to leverage their competitiveness through the usage of HPC.



End User



Domain Expert



HPC Centre & Provider



CESGA is part of the Spanish NCC.



The Challenge

Currently, aeronautical meteorological information is focused on providing the meteorological conditions at departure and arrival airports. Although this is sufficient for conventional aviation, it is not enough for Unmanned Aerial Vehicles (UAVs, so-called 'drones'). Due to their size and flying dynamics, drones are more vulnerable to their surroundings. Hence, one of the main factors to be considered in the operational safety of drones is accurate and reliable weather forecasting throughout the flight path.



Industry Sector:
Transportation
Technology used:
HPC

Find out more



The Solution

The experiment addressed the challenge of creating reliable weather forecasts appropriate for drones without expensive ground equipment, creating a solution dubbed HERCULES. The specially equipped weather impervious Meteodrone collected weather information during 150 flights over key locations in Galicia to provide the necessary data for the building of the forecast models. 4 different parametrized Weather Research and Forecasting (WRF) models were provisioned to compute accurate weather predictions in the region of Galicia in a timely manner, using HPC. Lastly, tools and services through the newly developed HERCULES website were provisioned.

The Impact

HERCULES' solution will enable safe and efficient drone operations by providing operators the capability to obtain dedicated weather forecasts at their flying altitudes without relying on expensive ground infrastructure. This service will be one of the keys to unlocking an emerging sector that is expected to grow by €10 billion annually until 2035. In addition, the live information provided by the Meteodrone could be used to support traditional manned aviation during landing procedures in aerodromes that cannot use ground infrastructure for weather predictions. HERCULES high-resolution local weather forecast models have the potential for future business opportunities in other industries – for example, wind energy or fishing in which accurate weather prediction could positively impact safety and efficiency.

Benefits

- High-resolution weather forecast without relying on ground infrastructure (saving €100k), providing capabilities to characterize atmospheric conditions at any location.
- A weather forecast optimised for UAVs can increase operational efficiency and safety.
- Using a subscription model, HERCULES could reach 2,000 users in the next 3 years with an expected revenue of €78k per year for Aslogic.



HPC Vessel Maintenance Optimization by Natural Language Assistance

Organizations

FIGAL Innova is a Spanish SME, a leader in marine surveying and maintenance engineering. FIGAL is specialized in assets such as maritime machinery, vessel hulls, containers, in more than 30 countries. **SREC Solutions** is an SME that offers an expert system platform for setting up Digital Assistants powered by AI and Natural Language Understanding to use in any connected textual and voice interface. **CESGA** is a public foundation that provides HPC services for R&D, supporting SMEs to leverage their competitiveness through the usage of HPC.



The Challenge

In order to improve the maintenance process in the maritime industry and to better integrate it with their overall digitalisation approach, companies are calling for the integration of virtual assistants into their maintenance processes. FIGAL Innova and SREC Solutions developed a Vessel Predictive Maintenance System to monitor and assist a vessel's crew and operators with predictive maintenance of the ship's machinery. However, a virtual assistant must also work in highly noisy environments, increasing the complexity of such command recognition.



Industry Sector: **Transportation**
Technology used: HPC, AI, ML

Find out more



The Solution

A Natural Language Processing system was developed and adapted to a set of the most commonly used commands in the sector, which works reliably in noisy environments. The solution is based on a noise filter that uses a DL technique to identify and train the correct model. Once trained, the model was subsequently integrated with mobile devices for spoken command recognition. After HPC training, the Natural Language Understanding (NLU) algorithm can now correctly work with an accuracy superior to 95% in environments with a noise level of up to 80 dBm using only software.

The Impact

FIGAL can offer a virtual assistant based on voice commands that have the potential to reduce up to 30% of maritime maintenance costs by shortening their duration by up to 15%, eliminating up to 30% of breakdowns, and reducing harmful maintenance gaps due to insufficient crew knowledge and awareness by up to 20%. SREC owns a proven technology that can be applied to many other sectors. CESGA will use the results for demonstration of the benefits for SMEs of using HPC. SREC and FIGAL are located in a small village far from the high-tech business centres of Europe. The results demonstrated that innovation can be driven by players in rural areas too, and thus that highly-qualified employment is possible in these areas. Marine transportation carries over 90% of the global merchandise trade, totaling 11 billion tons of cargo per year. Hence, the improvements in maritime logistical chains have tangible repercussions in every economic sector. In the short term, they reduce the risk of shortages of essential goods and can contribute to controlling inflation; in the medium to longer term, they could result in acceleration of economic growth, employment, and lower trade costs.

Benefits

- New robust vessel maintenance assistant can reduce the maintenance costs by 30%.
- SREC expects to apply technology to other sectors, with an increase of incomes of 20% yearly in the next 5 years.
- FIGAL and SREC expect to create 10 jobs in the next 3 years.
- CESGA will use these results to leverage the usage of the HPC and Spanish NCC by Spanish SMEs, increasing the number of SMEs using its infrastructure and services by 10% annually.



EUROHPC Joint Undertaking
eurohpc-ju.europa.eu



European Commission
www.ec.europa.eu

The research leading to these results has received funding from the European High-Performance Computing Joint Undertaking (JU) under grant agreement No 951745. The JU receives support from the European Union's Horizon 2020 research and innovation programme and Germany, Italy, Slovenia, France, Spain.

For further information, please visit:



www.ff4eurohpc.eu



www.linkedin.com/company/43366020



www.twitter.com/ff4eurohpc



www.youtube.com/@ff4eurohpc744

www.ff4eurohpc.eu

